

PWR-ICE125

PWR-ICE250

DSP-CONTROLLED PLATE AMPLIFIER

User Manual

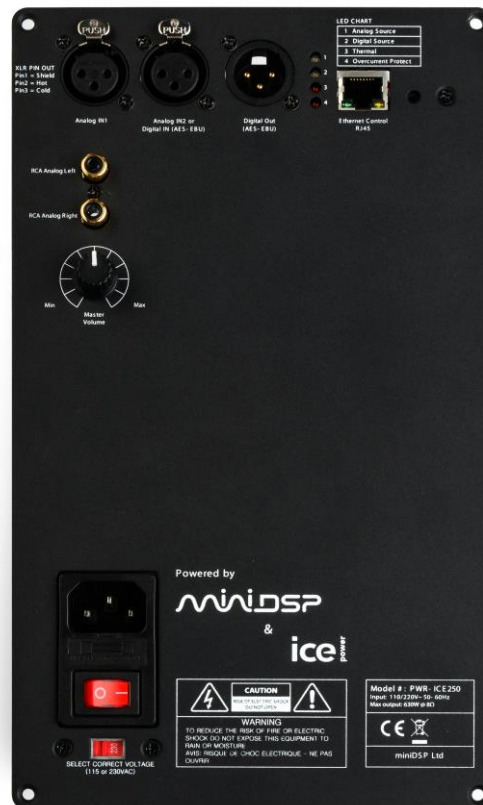

Revision history

Revision	Description	Date
V1.0	Initial revision	28-06-2013
V1.1	Updated typo on wiring	24-07-2013
V2.0	Merged PWR-ICE125 and PWR-ICE250; completely revised	31 August 2016
V2.1	Added 48k (FIR) plugin, new Master Volume selection	18 November 2016
V2.2	Changed plugin name	25 November 2016
V2.3	Updated support links	6 July 2020
V2.4	Adobe AIR and Flash no longer needed	1 February 2021

CONTENTS

Important Information.....	5
System Requirements	5
Disclaimer/Warning	6
Warranty Terms.....	6
Safety Instructions	7
1 Product overview.....	10
1.1 The miniDSP concept.....	11
1.2 Choosing a plugin	11
2 Installation and setup	12
2.1 Installation — Windows.....	13
2.1.1 Possible Windows installation issues.....	13
2.1.2 Plugin installation	13
2.2 Installation — Mac OS X	14
2.2.1 Possible Mac installation issues	14
2.2.2 Plugin installation	14
3 Hardware connectivity.....	15
3.1 High voltage WARNING	15
3.2 Main panel	16
3.3 AC Power	17
3.4 Analog audio input	18
3.4.1 Input sensitivity jumpers.....	18
3.5 Digital audio input and link/passthrough (AES/EBU)	19
3.6 Ethernet.....	20
3.7 Speaker connections	21
3.7.1 Output level jumper.....	21
4 Configuring the PWR-ICE Amplifiers	22
4.1 Connecting to a PWR-ICE amplifier	23
4.2 Mismatched plugins	24
4.3 Renaming an AMPLIFIER.....	25
4.4 Configuration preset selection.....	26
4.5 Master volume and mute	26
4.6 Input type selection.....	26
4.7 Channel mode	27
4.8 Amplifier mode	28
4.9 Mode combinations	29
4.10 Input channel configuration	30
4.10.1 Channel label.....	30
4.10.2 Gain adjustment and level monitoring	30
4.10.3 Parametric EQ.....	30

4.11	Output channel configuration.....	31
4.11.1	Channel label.....	31
4.11.2	Gain adjustment and level monitoring.....	31
4.11.3	Processing blocks.....	31
4.11.4	Mute.....	32
4.11.5	Invert.....	32
4.11.6	Time delay.....	32
4.12	Working with configurations.....	33
4.12.1	Selecting a configuration preset.....	33
4.12.2	Synchronization options.....	33
4.12.3	Saving and loading configurations.....	34
4.12.4	Restoring to defaults.....	35
4.13	Keyboard Shortcuts.....	35
5	Signal processing Functions.....	36
5.1	Parametric EQ.....	36
5.2	Crossover (96k plugin only).....	38
5.3	FIR filtering and design (FIR plugin only).....	39
5.3.1	FIR filtering overview.....	40
5.3.2	FIR filter design software.....	40
5.3.3	Filter file format.....	41
5.3.4	Loading filter coefficients.....	41
5.4	Custom biquad programming.....	42
5.4.1	What's a "biquad?.....	42
5.4.2	Using custom biquad programming.....	42
5.4.3	Biquad calculation spreadsheet.....	43
5.4.4	Room EQ Wizard (REW).....	43
5.5	Compressor.....	44
6	Additional information.....	45
6.1	Key Specifications.....	45
6.1.1	General.....	45
6.1.2	PWR-ICE125.....	45
6.1.3	PWR-ICE250.....	45
6.2	Mounting dimensions.....	46
6.2.1	PWR-ICE125.....	46
6.2.2	PWR-ICE250.....	48
6.2.3	Additional mounting considerations.....	50
6.3	MCU Firmware upgrade.....	51
6.3.1	Put the amp into bootloader mode.....	51
6.3.2	Windows.....	51
6.3.3	Mac.....	52
6.4	Troubleshooting.....	53
6.5	Obtaining Support.....	54



IMPORTANT INFORMATION

Please read the following information before use. In case of any questions, please contact miniDSP via the support portal at support.minidsp.com.

SYSTEM REQUIREMENTS

To configure the PWR-ICE amplifiers, you will require a Windows PC or Apple Mac OS X computer with the following minimum specification:

Windows

- PC with 1GHz or higher processor clock speed. Intel® Pentium®/Celeron® family, or AMD K6®/AMD Athlon®/AMD Duron® family, or compatible processor recommended.
- 512 megabytes (MB) of RAM or higher
- Keyboard and mouse or compatible pointing device
- Microsoft® Windows® Vista® SP1/ XP pro SP2/Win7/Win8.1/Win10
- Microsoft® .NET framework v3.5 or later

Mac OS X

- Intel-based Mac with 1 GHz or higher processor clock speed
- 512 megabytes (MB) of RAM or higher
- Keyboard and mouse or compatible pointing device
- Mac OS X 10.8 or higher

Both Platforms

For Ethernet connectivity via LAN:

- Ethernet router with spare 100 Mbps port

For direct (ZeroConf) Ethernet connectivity:

- Ethernet port on computer with 100 Mbps capability. (Recent Apple Macs: a Thunderbolt port with a Thunderbolt to Ethernet adapter.)



DISCLAIMER/WARNING

miniDSP cannot be held responsible for any damage that may result from the improper use of this product or incorrect configuration of its settings. As with any other product, we recommend that you carefully read this manual and other technical notes to ensure that you fully understand how to operate this product. The PWR-ICE amplifier is a powerful tool, and misuse or mis-configuration, such as incorrectly set gains or excessive boost, can produce signals that may damage your audio system.

As a general guideline, you should perform the initial configuration of your PWR-ICE amplifier before enabling audio through any connected output device or amplification. Doing so will help ensure that the software is correctly configured.

Finally, note that the PWR-ICE amplifier is a very flexible device, and many of the questions we receive at the tech support department are already answered in this user manual and in the online application notes on the minidsp.com website. So please take the time to carefully read this user manual and the online technical support. Thanks for your understanding!

WARRANTY TERMS

miniDSP Ltd warrants this product to be free from defects in materials and workmanship for a period of one year from the invoice date. Our warranty does not cover failure of the product due to incorrect connection or installation, improper or undocumented use, unauthorized servicing, modification or alteration of the unit in any way, or any usage outside of that recommended in this manual. If in doubt, contact miniDSP prior to use.

SAFETY INSTRUCTIONS

- Read the information for use
- Please keep this user manual in a safe place during the lifetime of the product. The user manual forms an integral part of the product. Reselling of the product is only possible if the user manual is available. Any changes made to the product have to be documented in writing and passed on to the buyer in the event of resale.
- Heed all warnings.
- Follow all instructions.
- Do not use this product near water (for example, in damp rooms or near a swimming pool).
- Clean only with dry cloth.
- Do not cover the heat sink. Install in accordance with the user manual.
- Do not install near any heat sources such as radiators, heat registers, stoves, or other apparatus that produce heat.
- Protect the power cord from being walked on, pinched or damaged in any other way. Pay particular attention to plugs and the point where they exit from the Amplifier Unit.
- The product may only be used in accordance with the information provided in the user manual. Before and during the usage of the amplifier please ensure that all recommendations, especially the safety recommendations as detailed in the user manual, are adhered to. The Amplifier Unit is designed for the amplification of pulsed audio signals and the Amplifier Unit should only be connected to speakers with average impedance that is not lower than the impedances specified in the User's Manual.
- Do not place the product on an unstable cart, stand, tripod, bracket, or table. The device may fall, causing serious injury, and serious damage to the device itself.
- The Amplifier Unit can only be disconnected from the power supply by removing the plug, which must be freely accessible at all times. Unplug this Amplifier Unit during lightning storms or when unused for long periods of time.
- Refer all servicing to qualified service personnel.

Damages that require service

Unplug the Amplifier Unit from the mains supply and refer to your dealer/distributor or other authorized repair workshop. Servicing is required when

1. The power-supply cord or plug has been damaged,
2. Liquid has been spilled or objects have fallen into the amplifier,
3. The amplifier has been exposed to rain or moisture,
4. The amplifier has been dropped or suffered damage in any other way,
5. The amplifier exhibits a distinct change from its normal function or performance.



Servicing

Do not attempt to service this product yourself. As opening or removing covers may expose you to dangerous voltage or other hazards, the amplifier may only be opened by qualified personnel. Please refer to your dealer/distributor.

Servicing and Replacement Parts

All service and repair work must be carried out by an authorized dealer/distributor. When replacement parts are required, please ensure that the dealer/distributor only uses replacement parts specified by the manufacturer. The use of unauthorized replacement parts may result in injury and/or damage through fire or electric shock or other electricity-related hazards.

Safety Check

Upon completion of any service or repairs to this product, ask the dealer/distributor to perform safety checks to determine that the amplifier is in proper operating condition.

Read the information for use (user manual)

When shipping the product, always use the original shipping carton and packing materials. For maximum protection, repack the unit as it was originally packed at the factory.

Environments

Use this product only in E1, E2, E3 or E4 environments according to EN55103-2 “Electromagnetic compatibility – Product family standard for audio, video and audio-visual and entertainment lighting control apparatus for professional use – Part 2: Immunity”

Ventilation and heat sink

The heat sink is provided to ensure reliable operation of the Amplifier Unit and to protect it from overheating. The heat sink must not be blocked or covered. This product should not be installed unless proper ventilation is provided or manufacturer’s instructions have been adhered to.

Water And Moisture

Do not use this product near water (for example, in damp rooms or near a swimming pool).

Cleaning

Unplug the Amplifier Unit from the wall outlet before cleaning. Do not use liquid or aerosol cleaners.

Power-cord Protection

Power supply cords should be routed so that they are not likely to be walked on or pinched by items placed upon them or against them, paying particular attention to cords and plugs, and the point where they exit from the Amplifier Unit.

Lightning

For added protection of the product during lightning storms, or when it is left unattended and unused for long periods of time, unplug it from the wall outlet. This will prevent damage to the product due to lightning and power-line surges. Disconnection from the mains power supply can only be achieved by removing the plug from the mains socket and by external disconnection of all poles from the mains.

Interference of external objects and/or liquids with the appliance

Never push objects of any kind into this product through openings as they may touch dangerous voltage points or short out parts that could result in a fire or electric shock. Never spill liquid of any kind on the amplifier.

Accessories

Do not place this product on an unstable cart, stand, tripod, bracket, or table. The product may fall, causing serious injury, and serious damage to the product. Any mounting of the product should follow the manufacturer's instructions, and should use a mounting accessory recommended by the manufacturer.

Connecting

When you connect the Amplifier Unit to other equipment, turn off the power and unplug all of the equipment from the supply source. Failure to do so may cause an electric shock and serious personal injury. Read the user's manual of the other equipment carefully and follow the instructions when making the connections..

Sound Volume

Reduce the volume to minimum before you turn on the amplifier to prevent sudden high levels of noise which may cause hearing or speaker damage.



Output connectors

WARNING: Output connector marked with the lightning flashes indicate high voltages that are potentially life threatening. Wiring to these terminals requires installation by an instructed person and the use of ready-made leads or cords. Custom wiring should only be carried out by qualified personnel.

To prevent electric shock, do not operate the product with any of the conductor portion of the speaker wire exposed.

NOTE: For reasons of safety and performance, use only high-quality fully insulated speaker cables of stranded copper wire. Use the largest wire size that is economically and physically practical, and make sure the cables are no longer than necessary.

Precautions when connecting to MAINS IN

When mounting or connecting the product always disconnect it from mains. Only connect the product to an appropriate AC circuit and outlet, according to the requirements indicated on the rating plate.

If a power cut occurs while the amplifier is switched on, it will restart automatically once the power supply has been restored. All settings prior to the loss of power will be maintained.

IMPORTANT: Always connect the Product to mains through the MAINS IN connector on the Amplifier Unit.



DO NOT REMOVE MAINS CONNECTOR GROUND, IT IS ILLEGAL AND DANGEROUS.

1 PRODUCT OVERVIEW

Thank you for choosing a miniDSP PWR-ICE DSP-controlled plate amplifier. This amplifier combines miniDSP's audio DSP (digital signal processing) expertise with the renowned ICEpower® amplification modules. It is capable of high-resolution (24-bit 96 kHz¹) audio processing and is available in two power output versions. Equipped with both analog and digital inputs, the PWR-ICE amplifiers are a flexible solution for any in-speaker DSP+power application. Optional "back boxes" can be purchased to convert the plate amplifiers into standalone amplifiers.

PWR-ICE125

This version of the PWR-ICE amplifier uses the ICEpower® 125ASX2 power amplification module, together with miniDSP's input and DSP hardware. Delivering up to 125 Watts per channel or a total of 450W in BTL mode, it is ideal for applications such as medium-powered two-way loudspeakers and subwoofers.

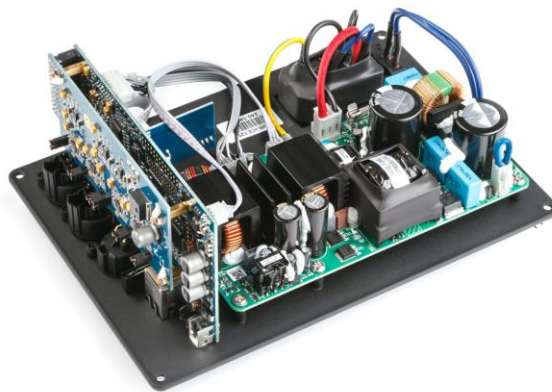

PWR-ICE250

This version of the PWR-ICE amplifier uses the ICEpower® 250ASX2 power amplification module, together with miniDSP's input and DSP hardware. Delivering up to 230 Watts per channel, it is ideal for applications such as high-powered two-way loudspeakers.

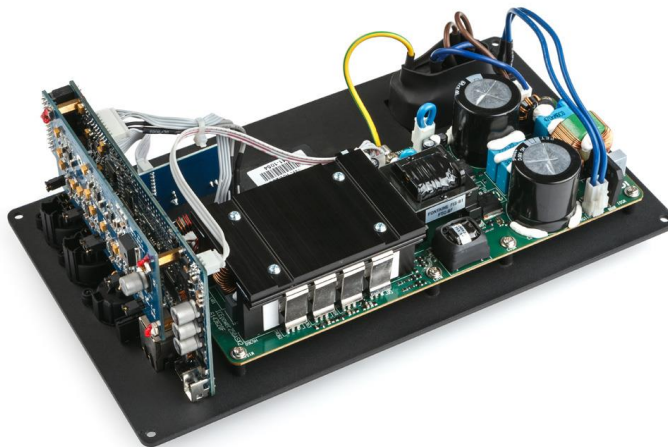

¹ With the 96 kHz version of the software plugin.

1.1 THE MINIDSP CONCEPT

The miniDSP concept is “one hardware unit + one software plugin = audio processing solution.” This concept leverages the inherent flexibility of DSP (digital signal processing) to deliver a range of flexible but cost-effective solutions.



Hardware unit

In this case, the hardware unit is one or more PWR-ICE amplifiers.

Software plugin

The software plugin is installed on your PC or Mac, and determines the processing that the DSP will perform. It provides a friendly user interface, and downloads instructions over the network into the amplifiers that tell them how to process the audio signal.

1.2 CHOOSING A PLUGIN

There are two plugins that operate with the PWR-ICE amplifiers. They are summarized below.

Table 1. PWR-ICE plugins

	PWR-ICE2-2x2	PWR-ICE2-2x2-FIR
Internal sample rate	96 kHz	48 kHz
Number of input channels	1 or 2	1 or 2
Number of output channels	1 or 2	1 or 2
IIR crossover	6 to 48 dB/octave	—
Number of FIR taps (for crossover and driver correction)	—	2300+300
PEQ bands per input channel	12	12
PEQ bands per output channel	6	6
Compressor block	✓	✓
Max per-channel time delay	10 ms	21.87 ms

Both plugins are included with the purchase of a PWR-ICE amplifier.

2 INSTALLATION AND SETUP

If you purchased your product directly from miniDSP, your software will be available from the [User Downloads](#) section of the miniDSP website when your order ships. To access the download, you will need to be logged into the website with the account you created when purchasing 96k plugin.

If you purchased your product from a miniDSP dealer, you will receive a coupon together with the product. Redeem this coupon and select the Plugin Group “PWR-ICE125/250” at the link below:

- <https://www.minidsp.com/support/redeem-coupon>

The User Downloads link is visible from the dropdown menu at the top right of the website page:

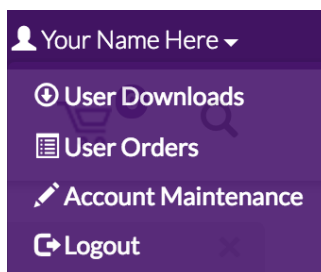

Navigate to the **PWR-DSP/PWR-ICE software** section. There you will find two packages available for download:

PWR-ICE 2x2 plug-in - Mac&Windows support

This will install the **PWR-ICE2-2x2** plugin. This manual will refer to this plugin as the “96k plugin.” Download this file for both Windows and Mac.

PWR-ICE 2x2 FIR plug-in

This will install the **PWR-ICE2-2x2-FIR** plugin. This manual will refer to this plugin as the “FIR plugin.” Download this file for both Windows and Mac.

After downloading, unzip the downloaded files (on Windows, right-click and select “Extract All...”; on Mac, double-click).

2.1 INSTALLATION — WINDOWS

2.1.1 Possible Windows installation issues

The miniDSP software requires that a number of other frameworks be installed for it to work. For Windows 7 and later, these packages should be installed automatically. For earlier versions of Windows, please download and install the following frameworks before attempting to install any miniDSP software. You can also manually install these if you receive an error message that required software is missing.

- [Microsoft .NET framework](#) (version 3.5 or later)
- Microsoft Visual C++ 2010 Redistributable Package: for [x86](#) (32-bit operating system) or [x64](#) (64-bit operating system).

2.1.2 Plugin installation

Note: if you are upgrading from version 1.2 or earlier of the 96k plugin, uninstall that plugin from the Control Panel before attempting an install.

- Navigate to the **Windows** sub-folder of the unzipped download.
- Double-click on the **PWR_ICE2_2x2.exe** or **PWR_ICE2_2x2_FIR.exe** installer program to run it. We recommend that you accept the default installation settings.

Once installation is complete, the plugin user interface will automatically start. Since the software checks for a network connection when starting up, a warning such as the following may appear. If so, ensure that “Private networks...” is checked and “Public networks...” is not checked. Then click on “Allow access.”



2.2 INSTALLATION — MAC OS X

2.2.1 Possible Mac installation issues

If double-clicking on an installer brings up a message that the installer cannot run, use this alternate method:

1. Right-click on the installer (or click while holding the Control key).
2. On the menu that pops up, move the mouse over the “Open With” item and then click on “Installer (default).”

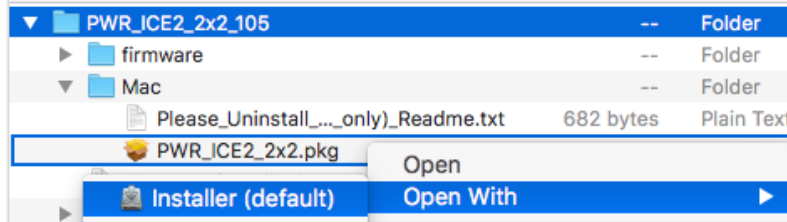

3. The following window will appear. Click on “Open.”

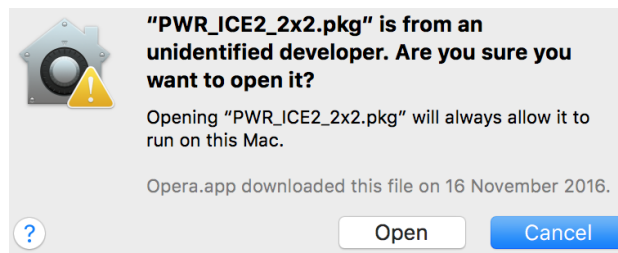

2.2.2 Plugin installation

- a. Navigate to the **Mac** sub-folder of the unzipped utility program download.
- b. The installer program is named **PWR_ICE2_2x2.pkg** or **PWR_ICE2_2x2_FIR.pkg**. To run it, double-click on it, or right-click and open as described above. We recommend that you accept the default installation settings.
- c. To run the plugin, locate **PWR_ICE2_2x2.app** or **PWR_ICE2_2x2_FIR.app** in the Applications -> miniDSP folder and double-click on it. To make it easier to run in future, right-click on its dock icon and select Options -> Keep in Dock.

3 HARDWARE CONNECTIVITY

3.1 HIGH VOLTAGE WARNING



To prevent electric shock, do not operate the product with any of the conductor portion of the speaker wire exposed. The PWR-ICE125 operates at hazardous voltage. For this reason, you should never operate the plate amplifier and touch the rear of the unit.

ALWAYS DISCONNECT THE AC POWER FROM THE UNIT BEFORE DOING ANY MODIFICATION TO YOUR PLATE AMPLIFIER.

Refer to the diagram below showing the rear of the unit. All red sections are **live** (primary AC wall voltage). **Never** operate this plate amplifier without proper installation (i.e. mounted to your speaker).

Always plan for a clearance of 12mm with any elements of the rear of the module for a safe distance.

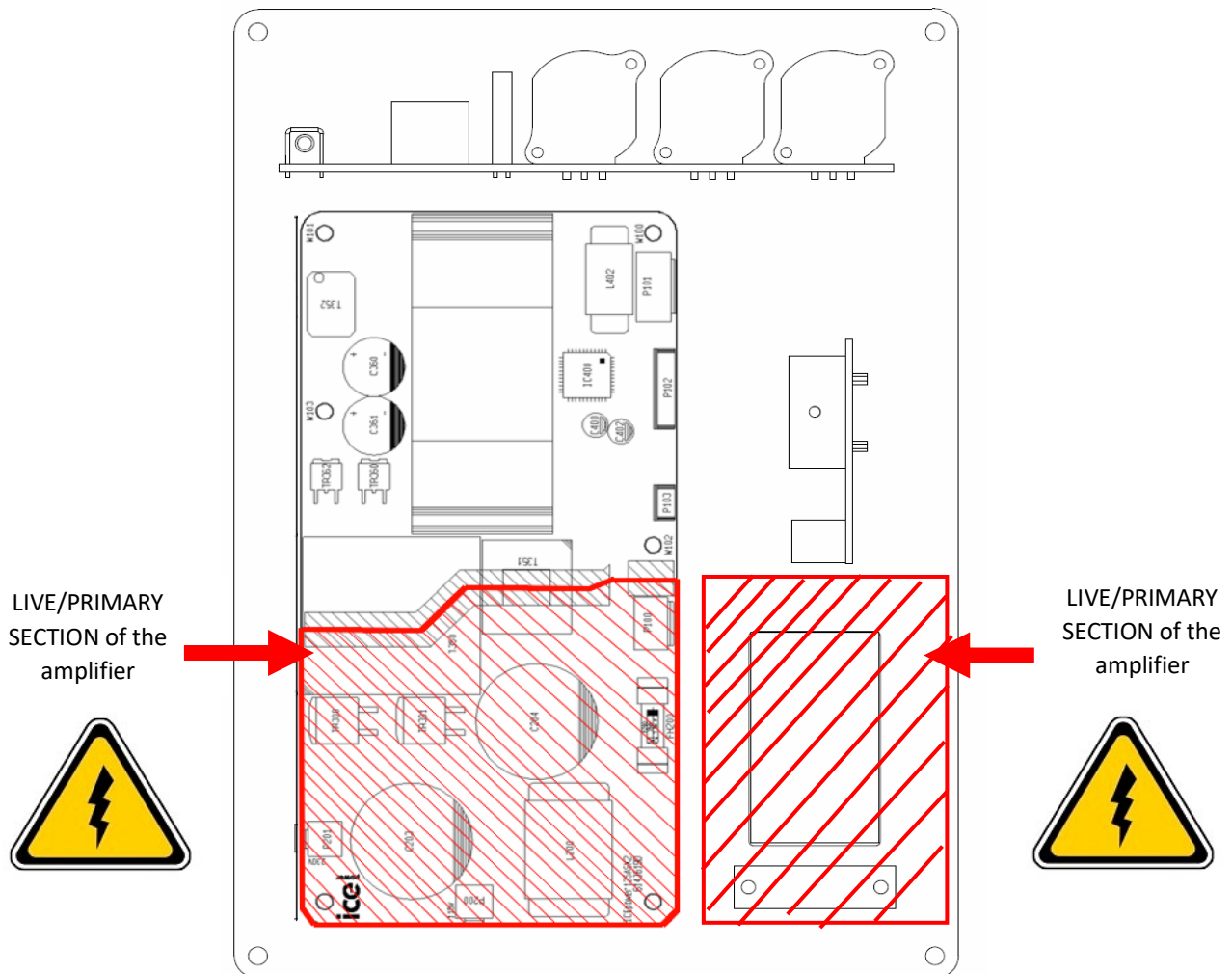

3.2 MAIN PANEL

Connections are made on the main panel, with the exception of the speaker outputs. (The PWR-ICE125 is shown here – the PWR-ICE250 is the same but longer.)

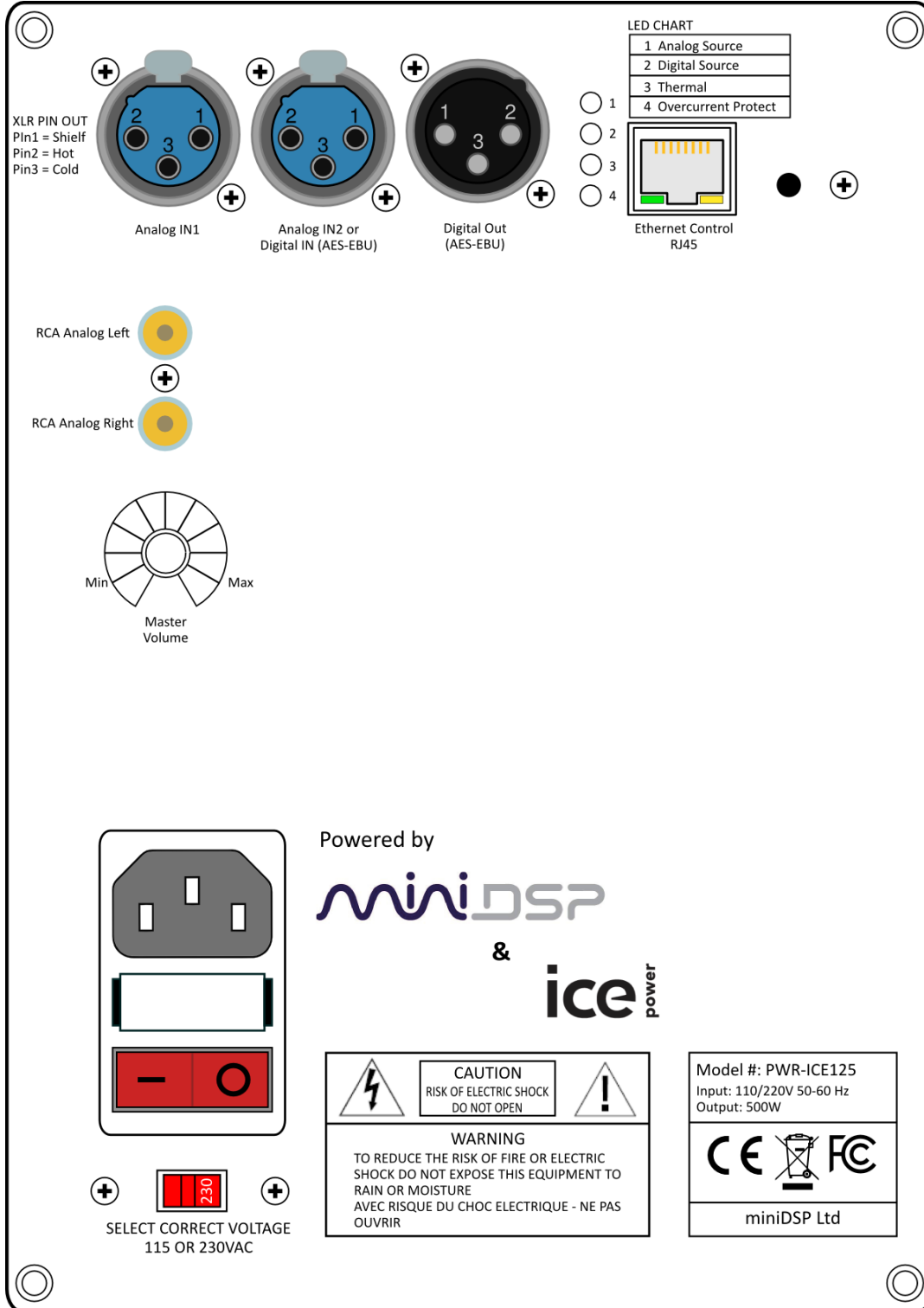

3.3 AC POWER

Connect AC power using the supplied IEC power cord. Before connecting, ensure that the voltage selector is set to the correct value for your country (115 or 230 V).

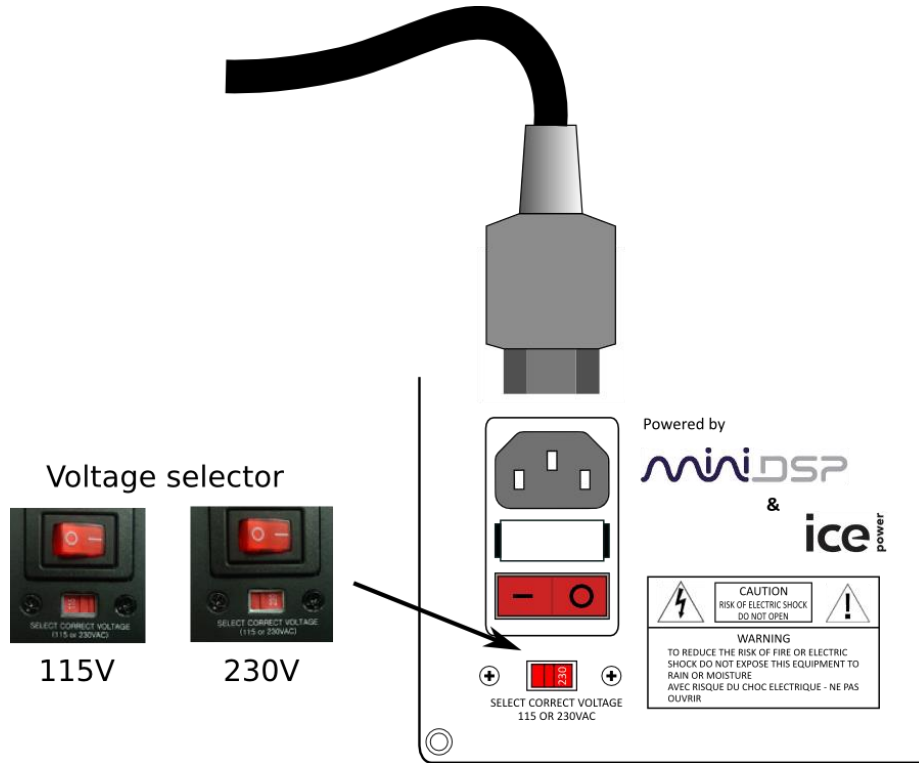

The PWR-ICE amplifier **must** be configured for the correct AC voltage. Our team will “pre-configure” the module based on your choice in the shopping cart, but make sure to double-check before powering on the amplifier.

3.4 ANALOG AUDIO INPUT

Connect analog inputs to **either** the RCA (single-ended) or the XLR (balanced) connectors. The amplifier must be configured for analog input (see [Input type selection](#)).

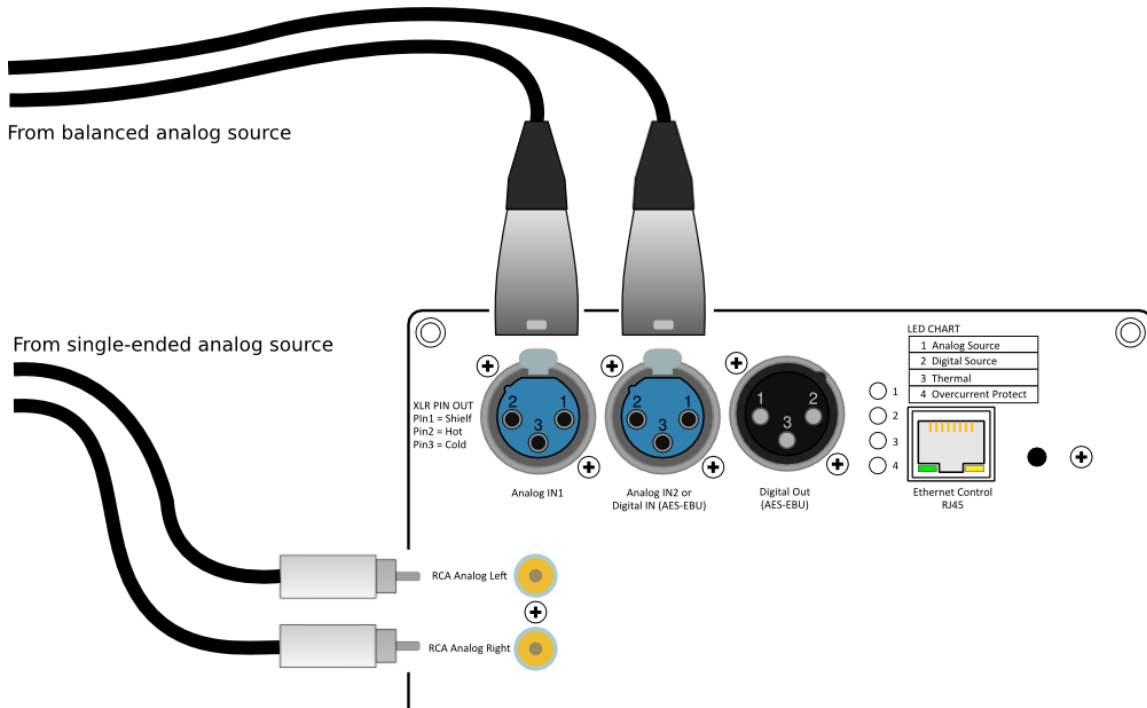

If connecting more than one PWR-ICE amplifier to a single source channel (for example, if connecting a subwoofer as well as a speaker to a preamplifier output), use a Y-splitter adapter or cable. Check the specifications for your preamplifier to ensure that the minimum specified load impedance is less than 10 k Ω /(number of connected PWR-ICE125 amplifiers).



Connect only RCA **or** balanced (XLR) inputs. Do not connect both at the same time.

3.4.1 Input sensitivity jumpers

The input sensitivity of the analog inputs can be changed with jumpers on the DSP board. There are three jumpers for each channel, and all jumpers for each channel must be set the same (i.e. all three open or all three closed).

Jumpers CLOSED:
 1 VRMS unbalanced
 2 VRMS balanced

Jumpers OPEN:
 2 VRMS unbalanced
 8 VRMS balanced

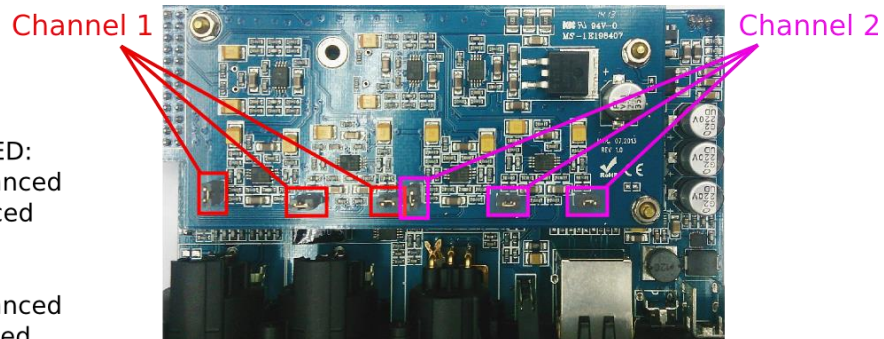

3.5 DIGITAL AUDIO INPUT AND LINK/PASSTHROUGH (AES/EBU)

If using the PWR-ICE with digital input, connect a balanced AES/EBU cable to **Digital IN**. The amplifier must be configured for digital input (see [Input type selection](#)). (This socket also functions as analog input channel 2 when the amplifier is configured for analog input.)

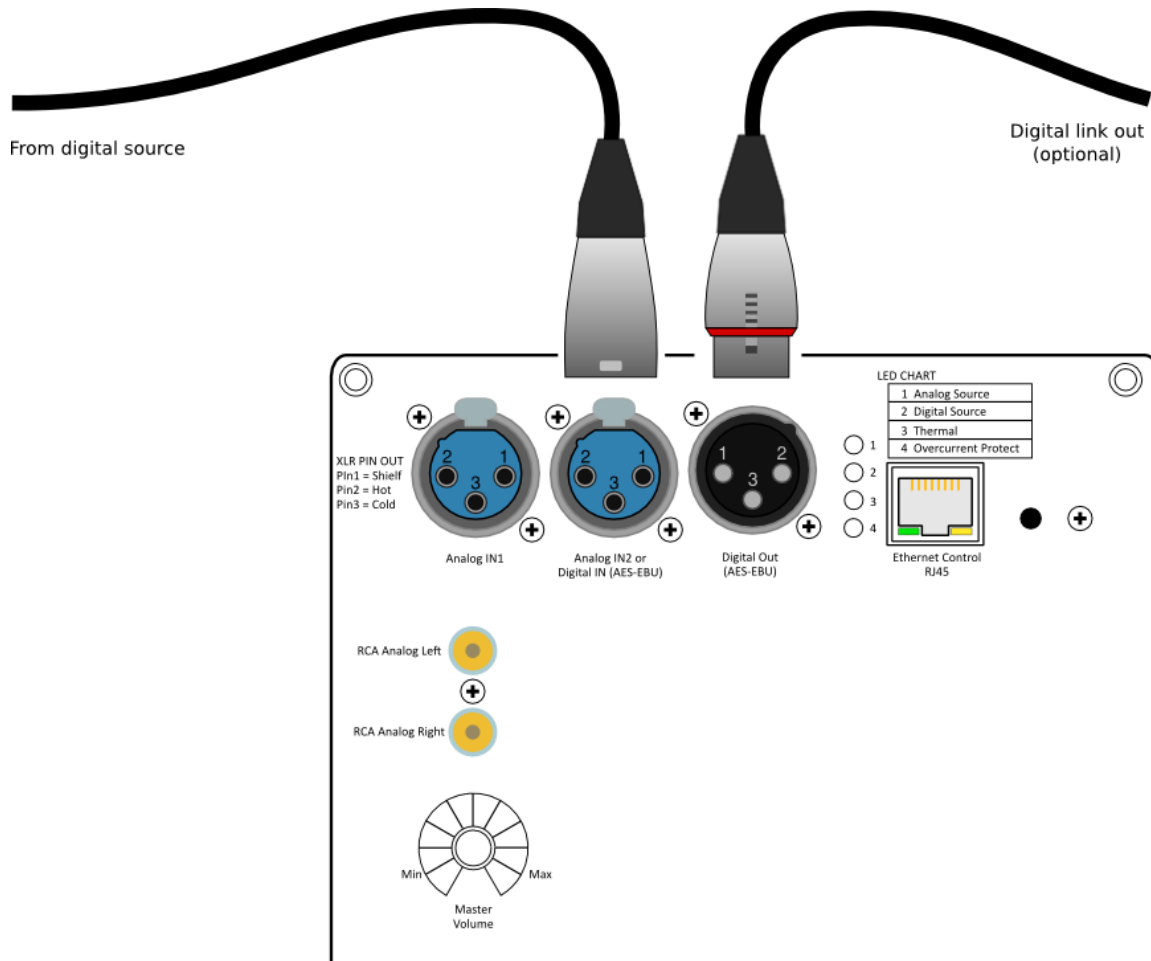

To connect equipment with only a single-ended (S/PDIF coax) output, we recommend using a transformer-based adapter such as those available from companies such as Neutrik, Canare and Switchcraft.

When the amplifier is in digital input mode and a digital input signal is connected, the input signal is buffered and presented on the **Digital Out** connector. This can be linked to a second amplifier. This is typically used for connecting the second amplifier of a pair (e.g. left and right), or for adding a subwoofer.

Note that the signal on **Digital Out** is a buffered version of the signal presented to **Digital IN** – that is, there is no resampling or reclocking of the digital signal. Multiple PWR-ICE amplifiers can therefore be daisy-chained to build more complex system configurations without signal degradation.



If the amplifier is set to analog input, there is no signal on the Digital Out.

3.6 ETHERNET

To configure the PWR-ICE amplifiers, connect an Ethernet cable from each amplifier to an Ethernet router or switch. The diagram below illustrates a typical case where the Ethernet router also acts as a wireless base station, and is in turn connected to an ADSL/cable modem. It is also common for the ADSL/cable modem, Ethernet router, and wireless base station to be combined into a single unit.

In the setup illustrated, two PWR-ICE amplifiers are connected via an Ethernet cable to the Ethernet router, while the computer is connected to the LAN over Wi-Fi. The network must be capable of DHCP so that the PWR-ICE amplifiers will be given an IP (network) address.

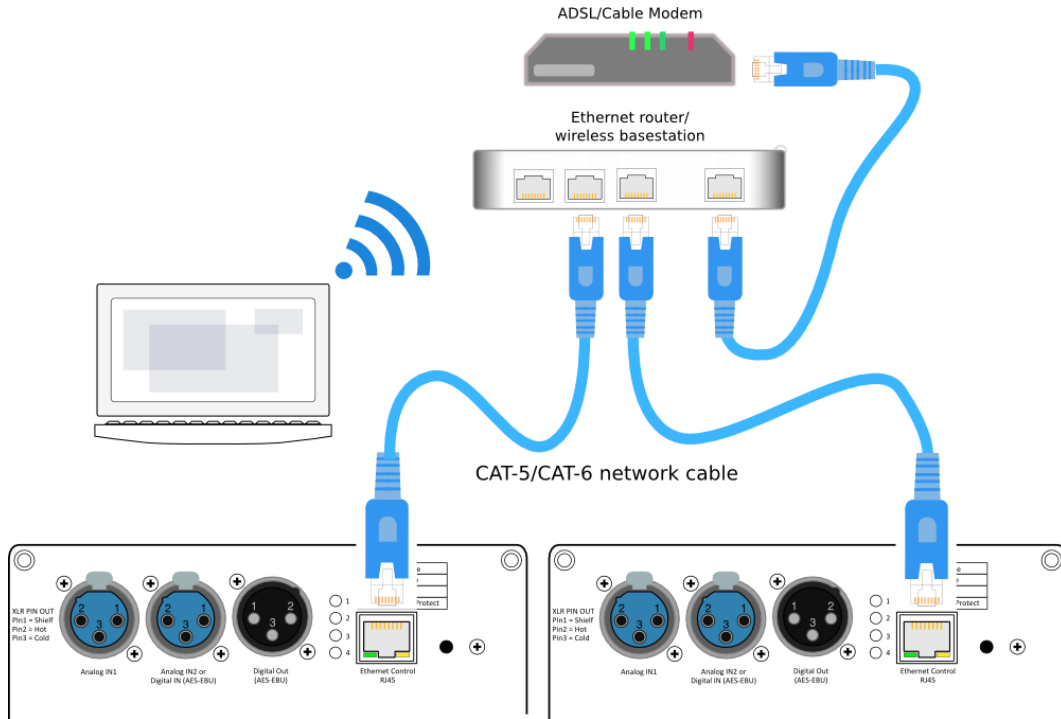

If a local area network is not available, or the network does not support DHCP, it is still possible to communicate with a single PWR-ICE amplifier over Ethernet: connect the computer to the amplifier directly with an Ethernet cable. In this case, auto-IP (link-local) addresses will be assigned. For this to work correctly, your PC must be set to allow automatic IP addresses (that is, it must not be set to a static IP address). You may also need to disable other network interface on the computer (for example, Wi-Fi).

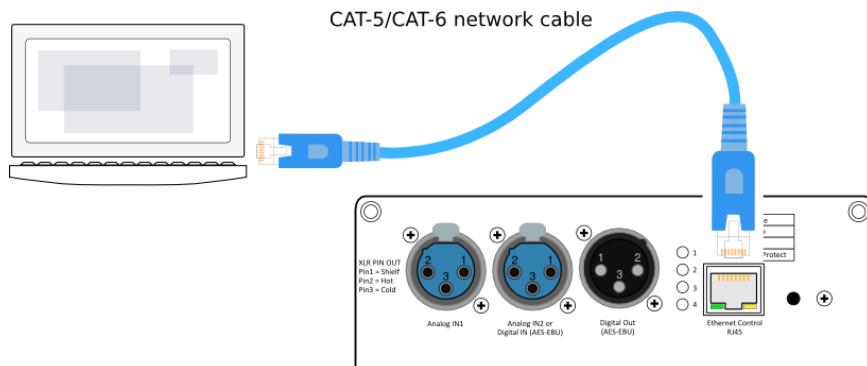

3.7 SPEAKER CONNECTIONS

Speaker connections are made using the supplied 4-way wiring harness. Connect the bare wire ends to the speaker driver or drivers (using crimp terminals if suitable), then plug the 4-way socket onto the 4-way 3.96 mm pitch header. The two connection options are shown in the diagram below.

2-ch mode

In 2-ch mode (also called SE or single-ended mode), the amplifier is connected to two speaker drivers. The plugin **must** be configured in 2-ch mode (see page 28), and the wiring connected to the two drivers with channel and polarity as shown on the left of the diagram below.

BTL mode

In BTL (bridge-tied load) mode, the amplifier is connected to a single speaker driver. BTL mode uses both “hot” wires as shown in the diagram below, and the “cold” wires are not used. The unused wires must be cut short or insulated to ensure that they do not contact anything. The plugin **must** be configured in BTL mode (see page 28).

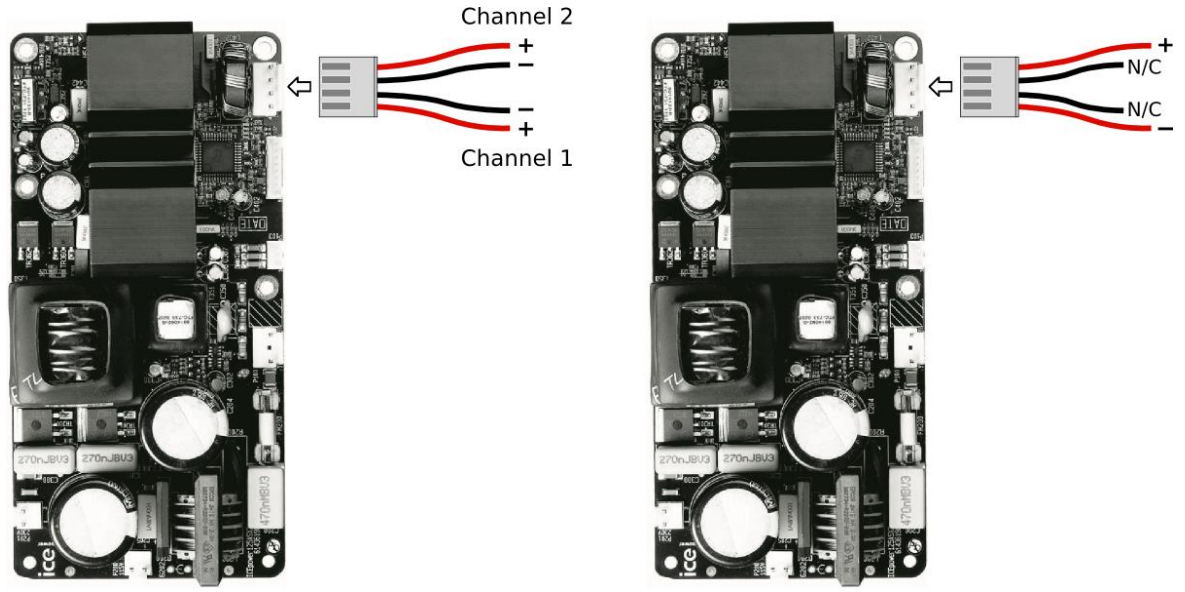

2-ch mode connection

BTL mode connection

3.7.1 Output level jumper

Either channel can have the analog output signal reduced by 16 dB by opening a jumper on the rear of the DSP board. This is used in situations such as a two-way loudspeaker with a sensitive tweeter.

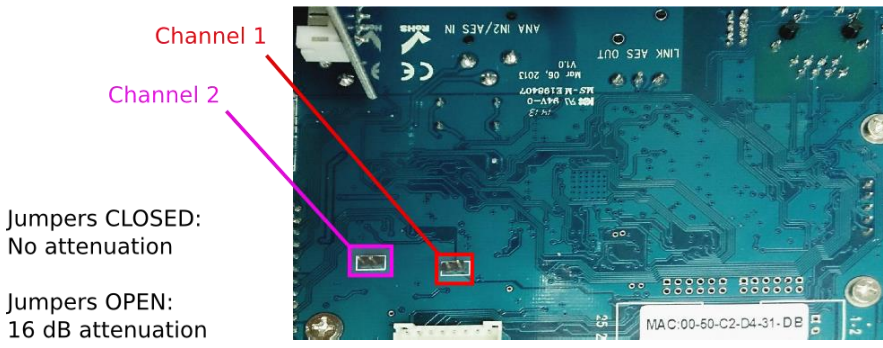

4 CONFIGURING THE PWR-ICE AMPLIFIERS

PWR-ICE amplifiers are configured with the **PWR-ICE2-2x2** plugin / user interface program. The plugin is used to manage all PWR-ICE amplifiers on the network.

This screenshot shows the user interface with the key areas highlighted:



Main menu

Used for operations like saving and loading configurations, restoring the amplifier to default settings, and firmware upgrades.

Config select

Selects one of four configuration presets (complete sets of audio processing settings) stored in the amplifier.

Device tree

Lists all amplifiers detected on the local area network.

Master volume and mute

Selects the master volume control mode, and mutes all audio from the amplifier.

Main control window

Contains all of the audio processing and control screens.

4.1 CONNECTING TO A PWR-ICE AMPLIFIER

To connect to an amplifier, expand the “Ethernet Device” node of the Device Tree, as shown below. (If you have more than one amplifier, you can rename each of them after connecting to it – see [Renaming an amplifier](#).)

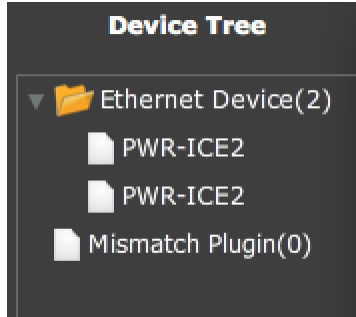

Click on the name of the desired amplifier. The following dialog will appear. The first time you connect to an amplifier, select the **Restore Config** option, to ensure that the amplifier contains a proper set of default settings. (On subsequent connections, if this dialog appears, you will usually select **Use onBoard Config** or **Synchronize Config**. See [Working with configurations](#) below.)

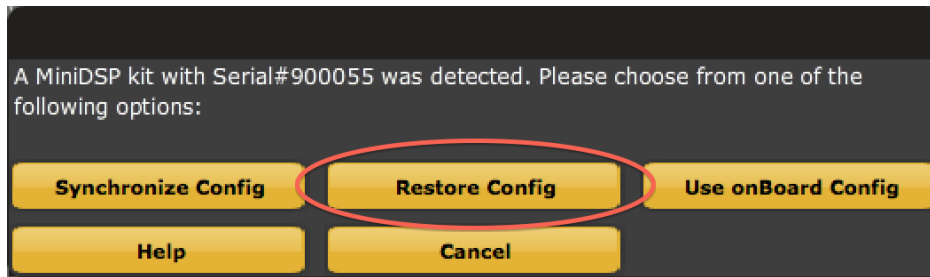

The plugin will download settings to the selected amplifier. Once connection is complete, the screen will update to show the connected amplifier:



The connected amplifier is now “live” and any changes made in the user interface will be immediately downloaded to it. This is referred to as *online mode*.



The **first time** you connect to an amplifier, we recommend that you go to the Restore menu and select the **Factory Default** option. This will ensure that all configuration presets are set to a proper initial state.

4.2 MISMATCHED PLUGINS

The device tree has, in addition to the “Ethernet Device” node, a “Mismatch Plugin” node. A PWR-ICE amplifier appears under this node when the plugin detects that the plugin loaded into the amplifier is not the same as the plugin running on the computer.

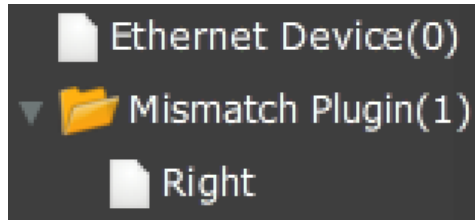

This can occur if:

- You have previously synchronized the amplifier using a different plugin. (For example, you previously synchronized with the 96k plugin but are now running the FIR plugin on your computer).
- The plugins have had a major upgrade that requires an incompatible configuration format. (This happens very infrequently).

To update an amplifier to the plugin that you are running on your computer, click on the amplifier’s name under “Mismatch Plugin.” You will see this dialog:

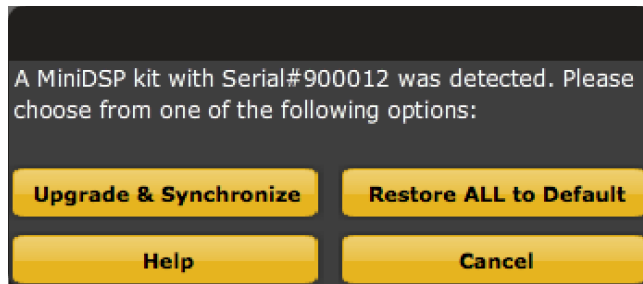

Click on “Upgrade & Synchronize.” The current configuration in the plugin will be downloaded to the amplifier. The amplifier should then re-appear under “Ethernet Device.”



Always check and if necessary reload your configurations after performing an “Upgrade & Synchronize” operation.

4.3 RENAMING AN AMPLIFIER

If you have more than one amplifier on the network, we suggest giving each of them a meaningful name. To rename an amplifier, you must first be connected to it. Then click on its name in the connection information area, delete the current name, and type a new name:



Then click the return key. The following dialog will appear:

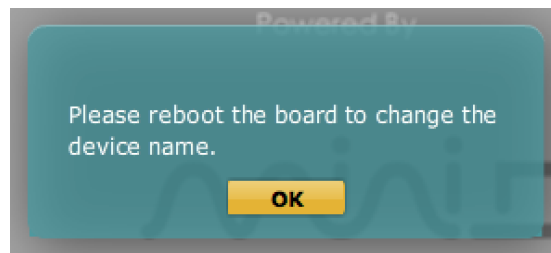

Turn the power to the amplifier off, wait a few seconds, and then turn the amplifier back on. After renaming the connected amplifiers, they will appear in the device tree with their new names.

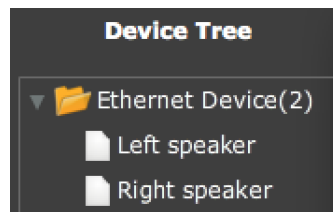

You can then click on each to complete configuration.

4.4 CONFIGURATION PRESET SELECTION

The PWR-ICE amplifier has four configuration presets stored in memory. These are selected with the row of buttons near the top of the screen. For more information on configurations, see [Working with configurations](#).

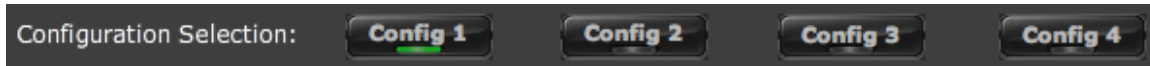

4.5 MASTER VOLUME AND MUTE

The Master Mute button enables and disables both output channels:



The Master Volume selection buttons control the way in which master volume control is done.

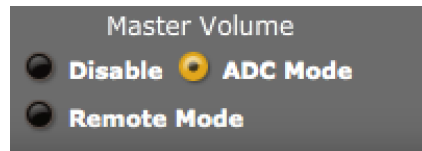

Disable Master volume control is disabled.

ADC Mode The knob on the amplifier panel controls master volume.

Remote Mode The miniDSP Android app controls master volume.

4.6 INPUT TYPE SELECTION

The PWR-ICE amplifier accepts either analog or digital input. Use the dropdown selector to choose the appropriate type. The connected cabling and signals must match the selected input type.

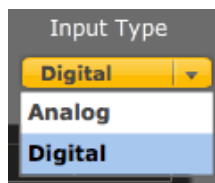

4.7 CHANNEL MODE

The **Channel mode** sets the way in which the PWR-ICE amplifier processes the input channels. It is selected near the top of the main control window.



Channel 1 (L) The left input signal only is processed.

Channel 2 (R) The right input signal only is processed.

Mixed L&R The left and right input signals are summed together for processing.

Stereo Both input signals are processed separately. When this mode is selected, **Amplifier mode** (see next page) must be set to **2-ch**.

The input channel strips at the left of the plugin user interface change depending on the selected channel mode:

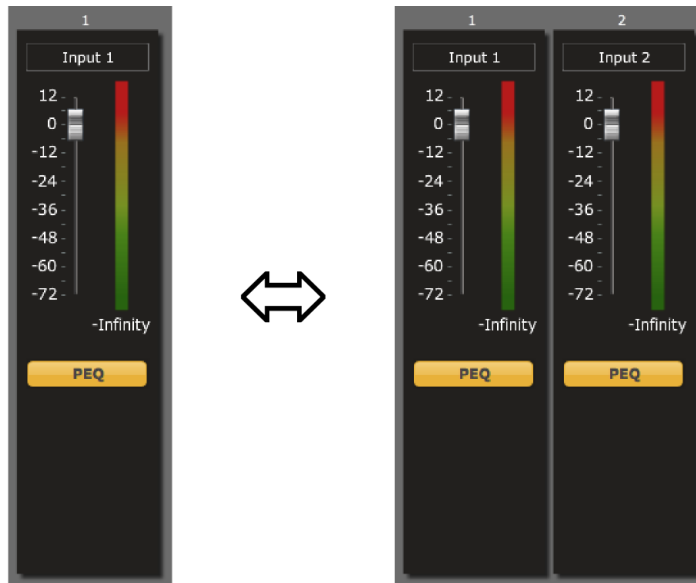

Channel 1 (L)
Channel 2 (R)
Mixed L&R

Stereo

4.8 AMPLIFIER MODE

The **Amplifier mode** sets how the two output channels are processed.



- 2-ch** The two amplifier channels operate independently. In the input mode **L**, **R**, and **Mixed L&R**, the same signal is fed to both channels. In **Stereo** input mode, each amplifier channel receives its respective input channel.
- BTL** The two amplifier channels are configured into BTL (bridge-tied load) mode. In this mode, the amplifier channels are driven out of phase, enabling higher power output into a single speaker or speaker driver.

The output channel strips at the right of the plugin user interface change depending on the selected amplifier mode:

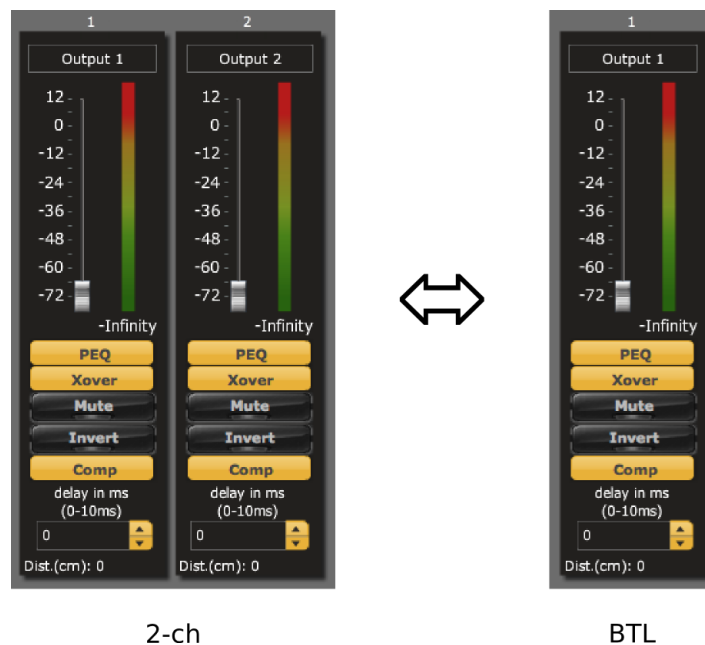

The physical connections to the speaker output terminals **must** be consistent with the selected amplifier mode. See page 21.

4.9 MODE COMBINATIONS

The combination of **Channel mode** and **Amplifier mode** determine how the amplifier is used. Table 2 summarizes the various mode combinations and the most typical use.

Table 2. Channel mode, amplifier mode, and typical usage

Channel mode	Amplifier mode	Typical usage
L	2-ch	Active crossover. Each output channel is connected to one speaker driver. Typically, one channel is used for the tweeter and one for the woofer (or woofers). A “FAST” configuration, where one channel is connected to a fullrange driver and one to a woofer, is another common use for this configuration.
R	2-ch	As above, but for the right speaker.
Mixed L&R	2-ch	This is not a very common configuration, but it could be used in a situation where a subwoofer contains two drivers, and each is driven by one amplifier channel, with the signal taken from the sum of the left and right input channels.
Stereo	2-ch	In this configuration, the PWR-ICE amplifier acts as a DSP-controlled stereo amplifier. One use is when the PWR-ICE amplifier is used together with the optional “back box” to create a standalone stereo amplifier. Another use can be a pair of powered speakers, where a single PWR-ICE amplifier module is located in one speaker box, and a speaker wire is taken across to a second speaker box (that doesn’t contain an amplifier).
L	BTL	In this configuration, a single PWR-ICE amplifier acts as a high-power “monoblock” amplifier for the left channel. Some possible uses are: <ul style="list-style-type: none"> • When multiple PWR-ICE amps are used in a single speaker, to power a single driver (typically the woofer). • With the optional “back box,” as a standalone DSP-controlled high power monoblock amplifier.
R	BTL	As above, but for the right speaker.
Mixed L&R	BTL	This is the most common configuration when the PWR-ICE amplifier is used to power a subwoofer. The whole amplifier drives a single subwoofer driver with the sum of the left and right input channels.

4.10 INPUT CHANNEL CONFIGURATION

One or two input control strips are shown in the user interface, depending on the channel mode.

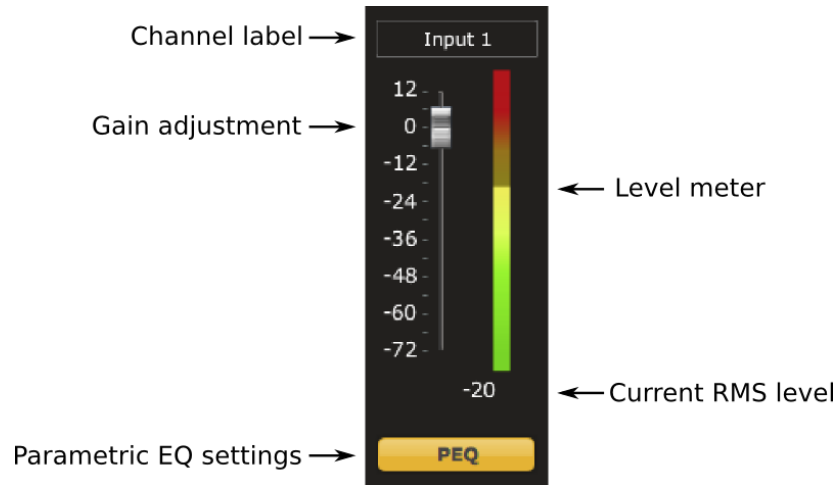

4.10.1 Channel label

The name of the input channel is shown at the top of the channel strip. To rename the channel, click on the channel label and type a new name (up to eight characters).

4.10.2 Gain adjustment and level monitoring

The gain of the input channel can be adjusted by moving the **Gain adjustment** slider, or by using the keyboard Up and Down arrows (after placing the focus on the slider – see [Keyboard Shortcuts](#)). The maximum gain setting is 12 dB and the minimum gain setting is -72 dB. (0 dB, the default, is unity gain or no change in level.)

The current signal level displays in two locations: on the bar-graph meter, and as a numeric value (in dB relative to full scale) underneath the bar-graph meter.

4.10.3 Parametric EQ

Each input channel has a parametric EQ block with 12 parametric filters. See the section [Parametric EQ](#) for full details.

4.11 OUTPUT CHANNEL CONFIGURATION

One or two output control strips are shown in the user interface, depending on the amplifier mode. The two plugins (48k and 96k) have a slightly different set of buttons.

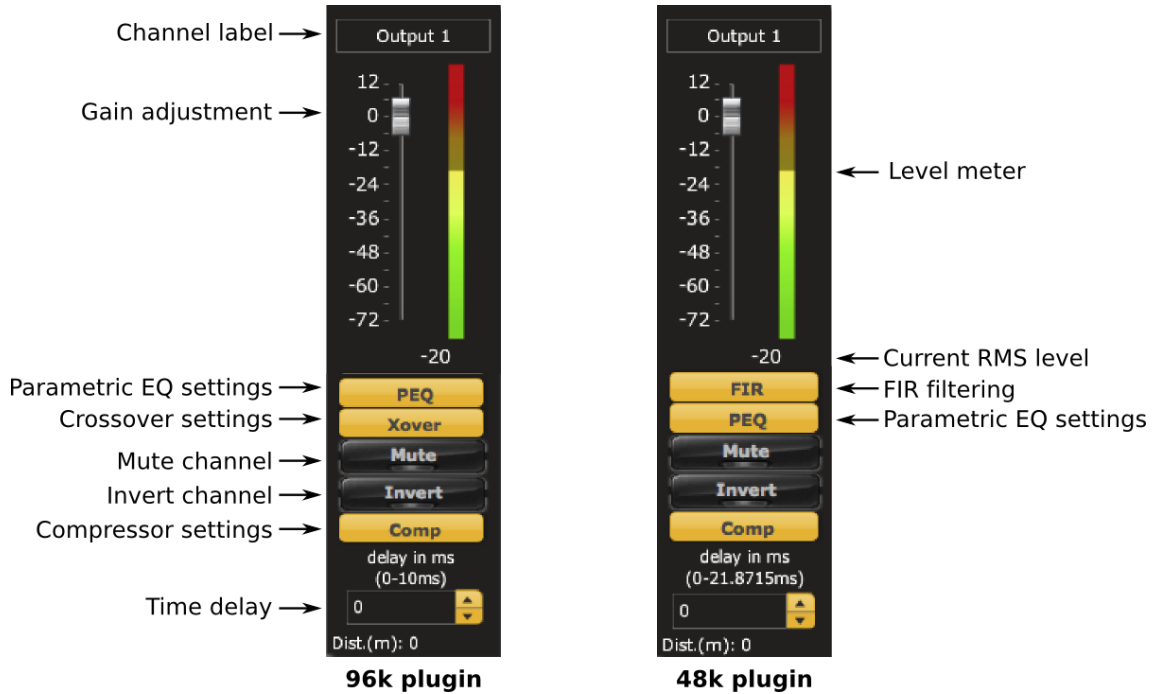

4.11.1 Channel label

The name of the output channel is shown at the top of the channel strip. To rename the channel, click on the channel label and type a new name (up to eight characters).

4.11.2 Gain adjustment and level monitoring

The gain of each output channel can be adjusted by moving the **Gain adjustment** slider, or by using the keyboard Up and Down arrows (after placing the focus on the slider – see [Keyboard Shortcuts](#)). The maximum gain setting is 12 dB and the minimum gain setting is -72 dB. (0 dB is unity gain or no change in signal level.)

The current signal level displays in two locations: on the bar-graph meter, and as a numeric value (in dB relative to full scale) underneath the bar-graph meter.

4.11.3 Processing blocks

Each output channel has a parametric EQ block with six parametric filters and a compressor/limiter. The 96k plugin has an IIR crossover block, while the FIR plugin has an FIR filter block.

See [Signal processing functions](#) for full details on these processing blocks.

4.11.4 Mute

This button mutes the output channel. This is helpful when testing and refining your configuration. (For example, mute the tweeter to test the woofer, and vice versa.)

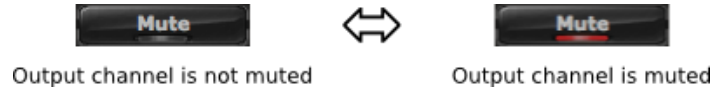

4.11.5 Invert

This button inverts the polarity of the output channel. In crossover applications, some slopes (e.g. 12 dB/octave) typically require that one of the output channels be inverted. In subwoofer applications, this can be helpful to improve integration with the main speakers.

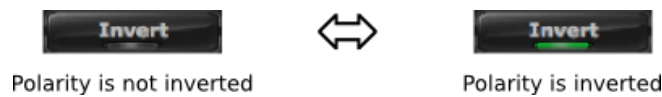

4.11.6 Time delay

A delay of up to 10 ms (96k plugin) or 21.875 ms (FIR plugin) can be applied to each output channel. To set the delay, click in the delay entry box for a channel. The delay value can be entered numerically, and the up and down arrows can be used to change the delay in small (0.02 ms) increments.

The time delay corresponds to a distance. This distance is shown in cm when the cursor is hovered over the time delay box.

Time delay can be calculated from distance using one of the following formulae:

$$(\text{Time delay in ms}) = (\text{Distance in cm}) / 34.4$$

Or:

$$(\text{Time delay in ms}) = (\text{Distance in inches}) / 13.54$$

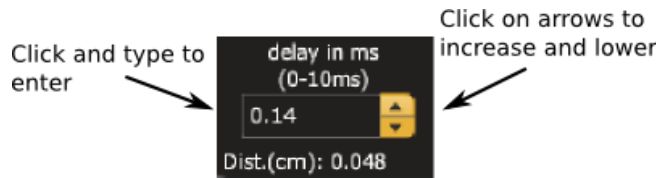

4.12 WORKING WITH CONFIGURATIONS

The complete set of data that controls the audio processing of the PWR-ICE amplifier is called a *configuration*. The PWR-ICE amplifier stores four configuration presets in its internal memory.

There are two modes of operation:

Offline mode

The plugin is running, but has not been connected to any amplifiers listed in the device tree. The “Now connected to” field will be blank and any changes made in the plugin will not be downloaded to any amplifiers. This is the state when the plugin is started. It can also occur in cases where communication with the amplifier is lost, such as a network issue.

Online mode

The plugin is connected to an amplifier, which displays on the “Now connected to” field. Any changes made to audio processing parameters in the plugin user interface are downloaded immediately to the PWR-ICE amplifier. The effect of these changes will thus be audible as the changes are made.

When the plugin goes into online mode, it checks to see whether its local state is consistent with the state of the amplifier. If not, it brings up a dialog asking you to choose what to do. See [Synchronization options](#).

4.12.1 Selecting a configuration preset

The current configuration is selected by the four buttons in the Configuration Selection area.



To switch to a different configuration preset, click on a different button. If the plugin is online, it first checks for consistency between the local and remote states of the selected plugin. If they are consistent, the real-time processing in the PWR-ICE amplifier will be updated to the newly selected configuration, and audio processing will then continue. If they are not consistent the dialog described in [Synchronization options](#) will appear.

4.12.2 Synchronization options

When the plugin detects an inconsistency between the local state and the amplifier state, it brings up this dialog:

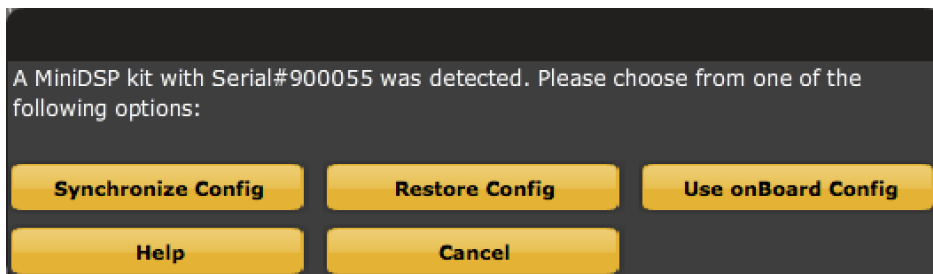

The options are:

Synchronize Config

Download the currently selected configuration into the corresponding configuration preset of the amplifier. The plugin will then be in online mode.

Restore Config

Restore the data in the currently selected configuration to the factory defaults, in both the plugin and the amplifier. The plugin will then be in online mode.

Use onBoard Config

Upload the configuration data from the amplifier to the plugin. The plugin will then be in online mode.

Help

This option brings up a help screen explaining the options.

Cancel

This option cancels the attempt to synchronize the plugin with the amplifier. If the plugin was offline, it remains offline; if the plugin was online, then it remains online but does not switch configurations.

4.12.3 Saving and loading configurations

Configurations can be saved to and loaded from files. Each configuration is stored in a separate file. It is strongly recommended that each configuration programmed into the PWR-ICE amplifier be saved to a file, to ensure that the configuration is not lost if the PWR-ICE amplifier is inadvertently reset.

To save the currently selected configuration to a file, drop down the File menu, then select **Save** and then **Save current configuration**. In the file box, select a location and name of the file, and save it.

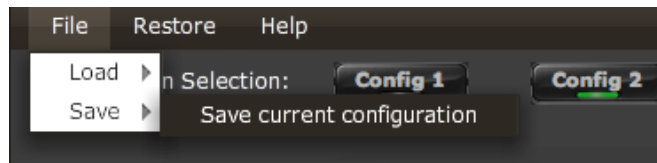

To load a configuration, first select the configuration preset that you wish to load the parameters into. Then drop down the File menu, select **Load**, and then **Load configuration to current slot**.

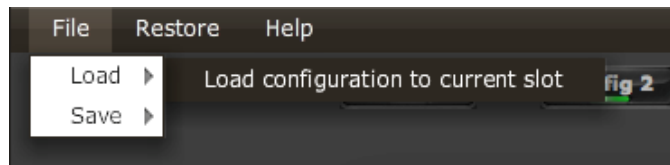

If the plugin is online, the loaded configuration data will be downloaded to the PWR-ICE amplifier immediately, and audio processing will recommence with the new settings. If the plugin is offline, the configuration data will be loaded into the user interface only.



To copy a configuration from one preset to another, save the configuration to a file, then select a different configuration preset and reload the file.

4.12.4 Restoring to defaults

Configurations can be reset to factory defaults from the **Restore** menu. There are two options:

Factory Default

Reset all four configuration presets to the factory default settings.

Current Configuration Only

Reset only the currently selected configuration preset to the factory default settings.

If the plugin is online, the default configuration data will be downloaded to the amplifier immediately. Otherwise, the reset will take place in the user interface only.



Each configuration should be selected and checked/initialized prior to connecting loudspeakers to the PWR-ICE amplifier.

4.13 KEYBOARD SHORTCUTS

The PWR-ICE amplifier user interface supports the use of the keyboard for many operations.

Tab The Tab key moves the focus from the current user interface element to the next. A light blue surrounding box usually indicates the user interface element with the focus. For example, after changing the frequency of parametric filter, the Tab key moves the focus to the gain control, so that the arrow keys can be used to change that channel's gain. Shift-Tab moves the focus in the opposite direction.

Up/down arrows

The up/down arrow keys adjust the value of many parameters:

- Output channel gain
- Crossover frequency and filter type
- PEQ filter frequency, gain, and Q

Space The Space bar toggles buttons that have two states, such as **Bypass**, **Invert**, and **Mute**. If the focus is on a control button such as **PEQ**, **Xover**, or **Comp**, the Space bar opens the relevant control screen.

5 SIGNAL PROCESSING FUNCTIONS

5.1 PARAMETRIC EQ

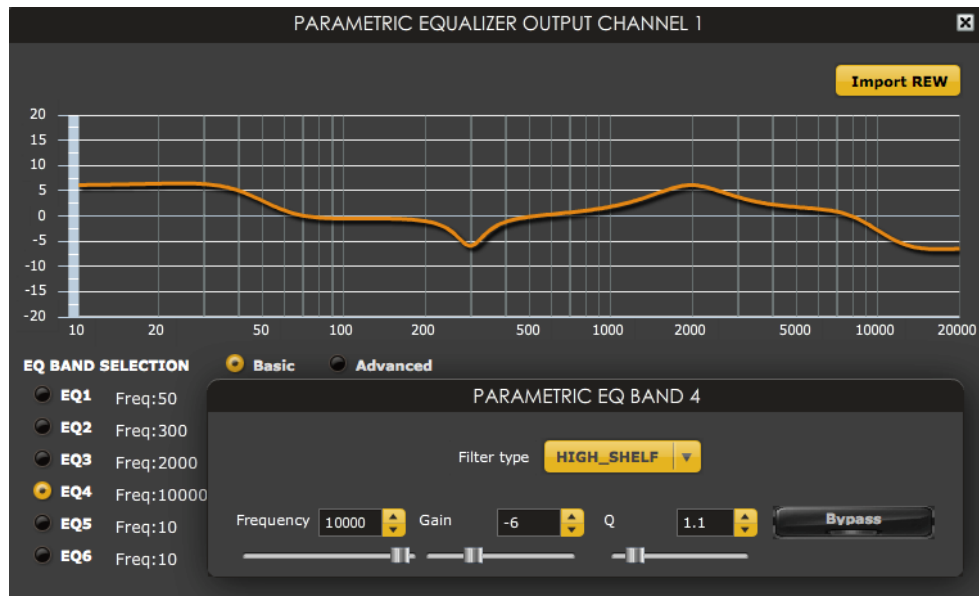

There is a parametric EQ (PEQ) block on each input channel and on each output channel. The input channel blocks each provide twelve parametric filters, while the output channel blocks each provide six parametric filters. A parametric filter can be set to a peaking boost or cut filter, high shelf filter, or low shelf filter.

The top section of the control panel shows the overall response curve of all six PEQ filters. Hovering the mouse over the curve brings up an overlay showing the frequency and the gain at that frequency.

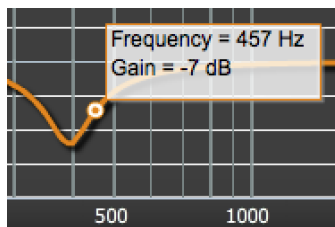

The example above shows (by way of example, this is not a typical setting) a response curve with four filters:

- A low-shelf filter with 6 dB boost, centered at 50 Hz
- A peaking filter with 6 dB cut (gain set to a negative value), centered at 300 Hz
- A peaking filter with 6 dB boost, centered at 2 kHz
- A high-shelf filter with 6 dB cut (gain set to a negative value), centered at 10 kHz



In detail, the parameters are as follows:

EQ band selection

Click on the radio buttons **EQ1**, **EQ2**, etc. to display the parameters for that filter.

Basic/Advanced

By default, each filter is in basic mode, and shows the controls described below. Advanced mode enables custom biquad programming for almost infinite flexibility in filter implementation. This is described in [Custom biquad programming](#).

Filter type

- | | |
|-------------------|--|
| PEAK | Create a dip or a peak in the frequency response. |
| LOW_SHELF | Reduce or increase part of the frequency spectrum <i>below</i> a given frequency. |
| HIGH_SHELF | Reduce or increase part of the frequency spectrum <i>above</i> a given frequency. |
| SUB_EQ | Create a dip or a peak in the frequency response at low frequencies (10 to 50 Hz). This filter type is similar to PEAK but gives more accurate results for low frequencies. Note that activating any SUB_EQ filter reduces the number of available filters in that block by one. |

Frequency

For the PEAK filter type, this is the center frequency of the peak or dip. For the HIGH_SHELF and LOW_SHELF filter types, this is the frequency at which the gain is half of the set value.

Gain

For the PEAK filter type, this is the gain in dB at the center frequency. For the HIGH_SHELF and LOW_SHELF filter types, this is the gain in dB reached at high or low frequencies respectively. A filter has no effect if its gain is set to 0. Gain can be adjusted in increments of 0.1 dB up to +/- 16 dB.

Q

Q controls the “sharpness” of the filter. For the PEAK filter type, lower Q gives a shallower peak or dip, while higher Q gives a narrower peak or dip. For the HIGH_SHELF and LOW_SHELF filter types, Q controls how quickly the filter transitions from no gain to maximum gain.

Bypass

Clicking on the **Bypass** button disables that filter. (All other filters are still operational unless individually bypassed.)

Import REW

This button selects a file exported from Room EQ Wizard’s automatic equalization function. For more information, see the section [Custom biquad programming](#) and the app note [Auto-EQ tuning with REW](#).

5.2 CROSSOVER (96K PLUGIN ONLY)

Each output channel of the PWR-ICE2-2x2 (96k plugin) has independent high pass and low pass filters. Click on the **Xover** button to open the crossover settings window:

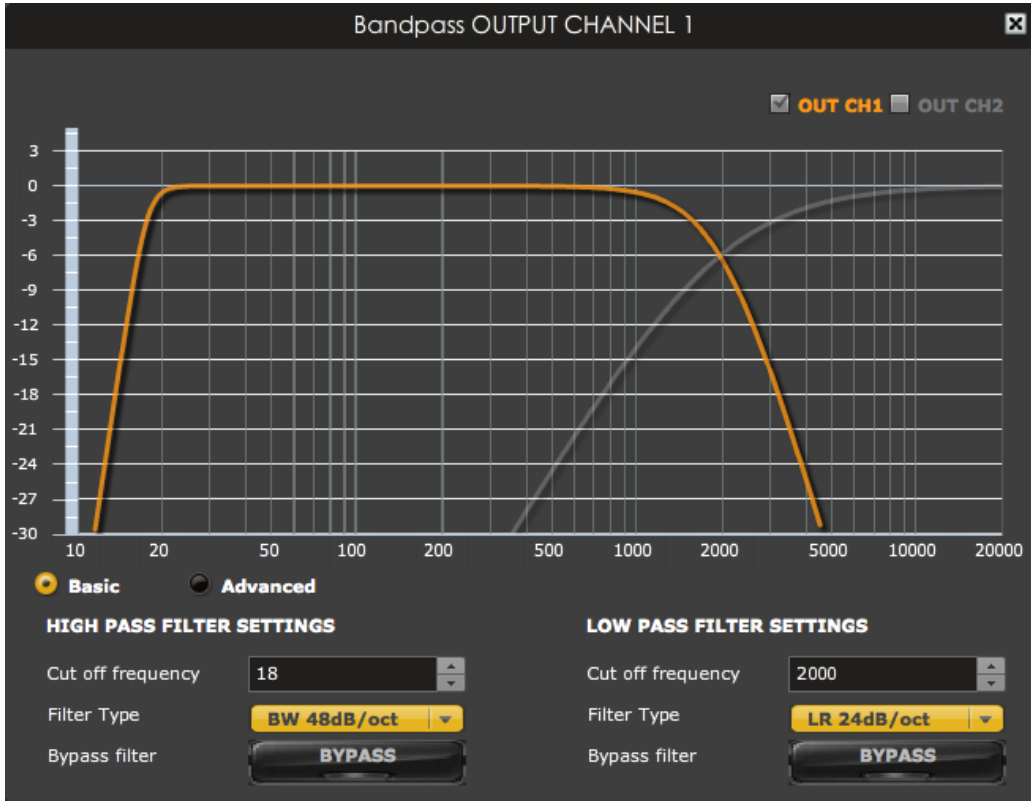

There is one filter for high pass (low cut) and one for low pass (high cut). The above example shows output channel 1 with a pair of filters: an 18 Hz high pass filter and a 2000 Hz low pass filter. Overlaid in light gray is the crossover filter for output channel 2, which is a high pass filter, also at 2000 Hz but with a different slope.

Each filter can be set to one of a range of filter types and slopes. The filter type determines the shape of the filter around the crossover point, and the filter slope (expressed in dB/octave) determines how steep the filter cutoff is.

Basic/Advanced

By default, the crossover is in basic mode, and shows the controls described below. Advanced mode enables custom biquad programming for almost infinite flexibility in crossover filter implementation. This is described in [Custom biquad programming](#).

Cutoff Frequency

Sets the nominal cutoff frequency of the crossover. In actual fact, of course, the crossover has a more or less gradual transition from “full on” to “full off,” as determined by the filter slope.

Filter type

Selects the type and slope of the filter. The steeper the slope, the more quickly frequencies above or below the cutoff frequency are attenuated. There are three types of filter:

Butterworth (BW)

Available in 6, 12, 18, 24, 30, 36, 42, and 48 dB/octave, Butterworth crossover filters are 3 dB down at the cutoff frequency.

Linkwitz-Riley (LR)

Available in 12, 24, and 48 dB/octave, Linkwitz-Riley crossover filters are 6 dB down at the cutoff frequency.

Bessel

Available in 12 dB/octave only, a Bessel filter gives a more gradual roll-off through the crossover region.

Bypass

Clicking on the **Bypass** button disables that high pass or low pass filter. (The other filter is still active, unless specifically bypassed also.)

5.3 FIR FILTERING AND DESIGN (FIR PLUGIN ONLY)

Each output channel of the PWR-ICE2-2x2-FIR (FIR plugin) has an FIR filter that can be used for driver correction and crossover. The filter banks are asymmetrical (they have different numbers of taps – see next page). FIR filtering allows construction of complex arbitrary equalization and crossover filters with independent control of amplitude and phase. The parameters of each FIR filter are set in the **FIR** settings window:

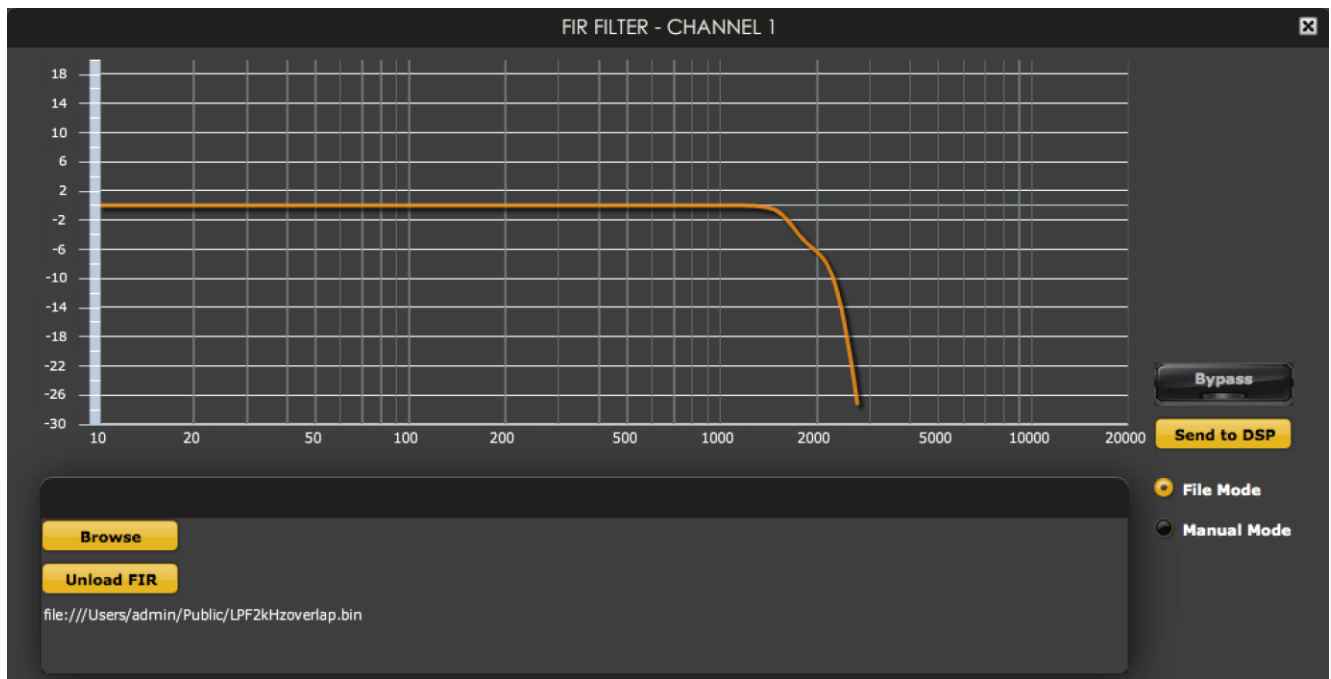

- Browse** Opens a filter browser to select a file containing FIR filter coefficients. (See FIR filter file format below).
- Unload FIR** Deletes the currently loaded filter coefficients from the plugin (all coefficients are set to zero).
- Bypass** Disables the FIR filter. The filter is disabled when the button is "lit."
- Send to DSP** Writes the current set of filter coefficients into the DSP memory.

File Mode / Manual Mode

In File Mode, the window displays the **Browse** and **Unload FIR** buttons as shown above. In Manual Mode, the display changes to allow direct text entry of the FIR filter coefficients, as shown below. The coefficients can be pasted into the window from a text editor.

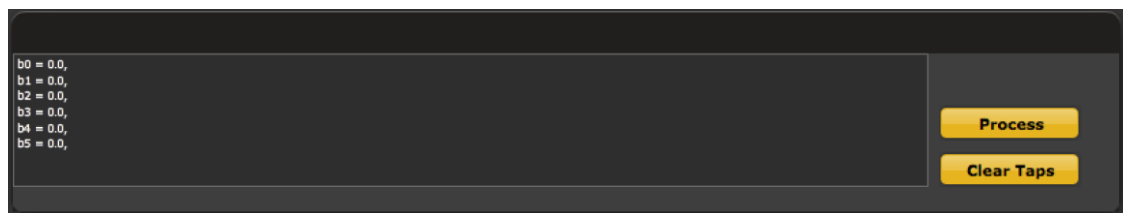

5.3.1 FIR filtering overview

FIR ("finite impulse response") filtering differs from the IIR ("infinite impulse response") filters used in the PEQ and crossover blocks. Technically speaking, IIR filters are *recursive*, meaning that each output value is partially calculated from earlier output values as well as from input values. An FIR filter is specified by a large array of numbers, whereas an IIR filter requires only a fairly small of values to be specified.

These numbers are conventionally referred to as "taps." The tap allocation is asymmetric:

- Output channel 1 has **2300** taps.
- Output channel 2 has **300** taps.

This tap allocation is suited for typical two-way crossover applications. The longer filter on output channel 1 allows for woofer correction down to reasonably low frequencies (frequency resolution is about 21 Hz) while the short filter on output channel 2 is suitable for typical crossover and driver correction for a tweeter.

Note that the delay on the woofer output channel will probably need to be set to allow for the different delays created by the two filters.

5.3.2 FIR filter design software

The filter coefficients must be created with the aid of filter design software. miniDSP does not provide any such software, instead referring you to the many software packages available for this purpose (both freeware and commercial). Please see the [FIR filter tools](#) page on our website.



Be sure to set the filter design software to use a 48 kHz sample rate. If not set to 48 kHz, the filters will not be correct.

5.3.3 Filter file format

The filter coefficient file loaded in **File Mode** uses [IEEE 754 single-precision binary floating-point format](#). The number of entries in the file must not exceed the allocated number of taps.

In Manual Mode, the coefficients must be plain text in this format:

```
b0 = 1,
b1 = -1,
b2 = 0.5,
b3 = -0.5,
b4 = 0.2,
b5 = 1,
```

5.3.4 Loading filter coefficients

In **File Mode**:

- Click **Browse**, navigate to the file containing the filter coefficients, and open it. A dialog will appear confirming the number of coefficients loaded.
- Confirm that the response curve is as you expect.
- Press **Send to DSP**. This will write the coefficients into the DSP's memory.
- To clear the filter coefficients, click **Unload FIR** and then **Send to DSP**.

In **Manual Mode**:

- Cut and paste the coefficients from the text output of the design program.
- Press the **Process** button.
- Confirm that the frequency response graph is as you expect.
- Press **Send to DSP**. This will write the coefficients into the DSP's memory.
- To clear the filter coefficients, click **Clear Taps** and then **Send to DSP**.



If, after selecting a filter file or setting coefficients, the frequency response graph does not change as expected, make sure that the filter is not bypassed.

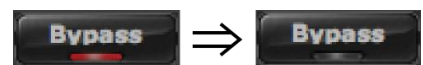

If you clear the filter taps, make sure that you also bypass the filter, otherwise there will be no audio through that channel.

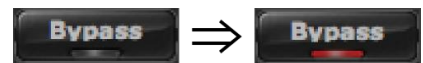

5.4 CUSTOM BIQUAD PROGRAMMING

Custom biquad programming is available in the parametric EQ and crossover blocks. Its purpose is to allow you to directly provide the low-level parameters aka *biquad coefficients* that control the digital filters, thus providing an almost infinite degree of flexibility.

For example, you can create hybrid crossovers with more than one cutoff frequency, create crossover filter types beyond those provided in the easy-to-use “basic” interface, implement a Linkwitz transform, or mix crossover and filtering biquads in the same block.

5.4.1 What’s a “biquad?”

A biquad is the basic unit of processing that is used to create digital filters. It can be described either with an equation or with a signal flow diagram, as shown here:

$$H(z) = \frac{b_0 + b_1 z^{-1} + b_2 z^{-2}}{1 + a_1 z^{-1} + a_2 z^{-2}}$$

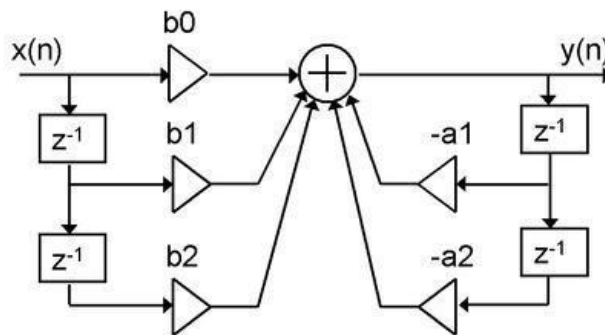

A single biquad like this can perform a great many functions, including all of the functions of a single parametric EQ filter, one 6 or 12 dB/octave high pass or low pass filter, and more. Biquads are combined in series (cascaded) to create more complex filters. The function that each biquad performs is determined by just five numbers: a_1 , a_2 , b_0 , b_1 , and b_2 . These numbers are called the *coefficients*.

5.4.2 Using custom biquad programming

Each crossover block and parametric EQ filter has a selector that switches it to advanced mode:



In advanced mode, the biquad coefficients are pasted directly into the user interface. These coefficients must be calculated using a filter design program – see the following sections for suggestions.

Note that when using a filter design program, the sample rate must be specified at the correct rate for the plugin – 48 kHz for the **PWR-ICE2-2x2-FIR** plugin, and 96 kHz for the **PWR-ICE2-2x2** plugin.

Parametric EQ advanced mode

In the parametric EQ blocks, advanced mode allows each individual filter to be specified by its coefficients. After pasting in the biquad coefficients, click on the **Process** button for them to take effect.

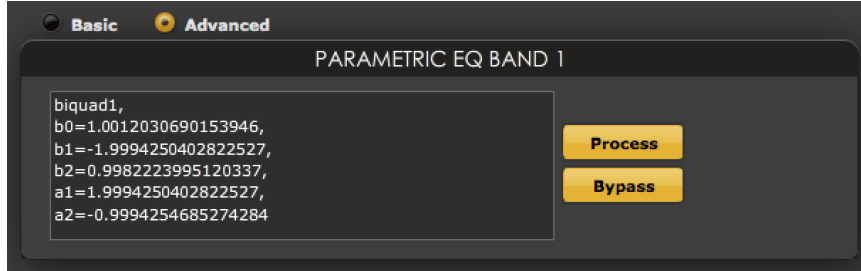

Parametric EQ file import

Six filters can be set at once by importing a coefficient file from Room EQ Wizard (REW). See [Room EQ Wizard](#) below.

Crossover advanced mode (96k plugin only)

Each **Crossover** block has eight biquads. In Basic mode, this provides high pass and low pass filters of up to 48 dB/octave. In **Advanced** mode, all eight biquads need to be specified. After pasting in the biquad coefficients, click on the **Process** button for them to take effect.

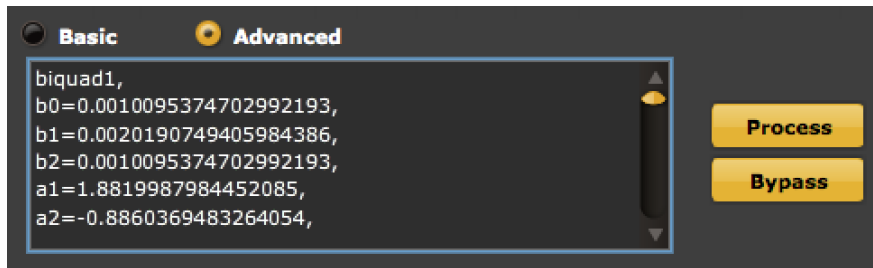

5.4.3 Biquad calculation spreadsheet

The community-developed biquad calculation spreadsheet allows more filter types to be calculated, including notch filters, Linkwitz transforms, and filters with arbitrary Q-factor. Access this spreadsheet here (requires Microsoft Excel):

- http://www.minidsp.com/images/fbfiles/files/All_digital_coefs_v1-20101026.zip

In the spreadsheet, each page has an **Fs** parameter. Be sure to set this to the correct sample rate for the plugin you are using – either 48 kHz or 96 kHz.

5.4.4 Room EQ Wizard (REW)

Room EQ Wizard is a free acoustic measurement and analysis tool, available for Windows, Mac and Linux platforms. It includes the ability to automatically generate a bank of parametric EQ biquads based on a

measurement. These coefficients can be saved to a file from REW and loaded directly into a PEQ bank in a miniDSP plugin. Room EQ Wizard can be downloaded here:

- <http://www.roomeqwizard.com/#downloads>

For guidance on using this feature, please refer to the app note [Auto EQ with REW](#). For the **Equalizer** setting, choose “MiniDSP” for the FIR plugin, and “MiniDSP-96k” for the 96k plugin.

5.5 COMPRESSOR

The compressor reduces the gain of an output channel when the audio signal reaches a certain level as specified by the **Threshold** parameter. The gain of the channel will be progressively reduced as the signal increases above the threshold, according to the **Ratio** parameter. This can be used to limit the power delivered to speakers and thus reduce the risk of damage from overdriving.

This screenshot shows an example Compressor setting:

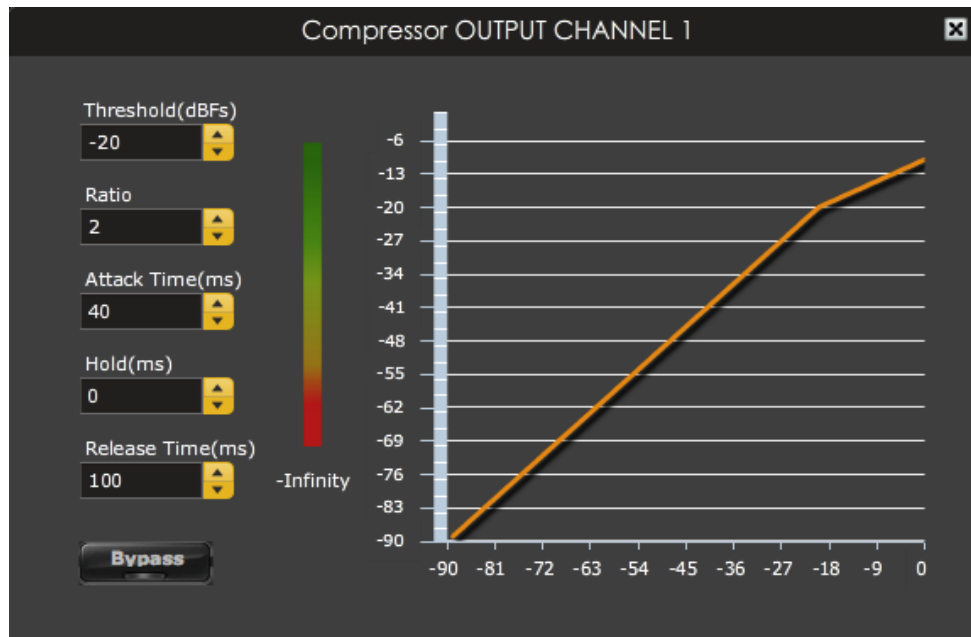

(Note that the compressor algorithm is bypassed by default, so click on the **Bypass** button to see the curve as shown here.)

In this example, the threshold is set to -20 dB, so the compressor will activate when the signal on that channel reaches -20 dB (relative to full output). The ratio is set to 2, so if the input signal level to the compressor then increases by 10 dB, the output level will increase by only 5 dB. If the input signal level to the compressor is at full scale (0 dB), then the output level will be limited to -10 dB.

Two additional parameters control the action of the compressor: the attack time and the release time. These two parameters govern how quickly the compressor activates when the signal level exceeds the threshold, and how quickly it deactivates when the signal level reduces. The optimum settings may need to be tuned by ear. For more information, see the Wikipedia article [Dynamic range compression](#).

6 ADDITIONAL INFORMATION

6.1 KEY SPECIFICATIONS

6.1.1 General

Analog inputs	Stereo RCA, 1V or 2V RMS maximum input (jumper selectable) Stereo balanced (XLR), 2V or 8V RMS maximum input (jumper selectable)
Digital input	AES/EBU, sample rates up to 216 kHz
Resolution	24-bit, 96 kHz
Protection features	Overcurrent and thermal overload protection
Supply voltage	85 to 132 VAC (switch set to “115V”) 170 to 264 VAC (switch set to “230V”)

6.1.2 PWR-ICE125

Power output, SE/2-ch mode, $R_L = 4\Omega^1$	120 W/channel (230V/50Hz AC) 105 W/channel (115V/50Hz AC)
Power output, BTL mode, $R_L = 4\Omega^2$	450 W (230V/50Hz AC) 370 W (115V/50Hz AC)
Dimensions (H x W x D)	153 x 216 x 77 mm

6.1.3 PWR-ICE250

Power output, SE/2-ch mode, $R_L = 4\Omega^1$	230 W/channel (230V/50Hz AC) 200 W/channel (115V/50Hz AC)
Power output, BTL mode, $R_L = 8\Omega^2$	500 W (230V/50Hz AC) 420 W (115V/50Hz AC)
Dimensions (H x W x D)	153 x 267.5 x 77 mm

- 1% THD+N_{SEP} 20Hz < f < 20kHz, both channels driven. (AES17 measurement filter). Specification provided by ICEpower. See ICEpower datasheets for 125ASX2 and 250ASX2 for full specifications.
- 1% THD+N_{SEP} 20Hz < f < 20kHz. (AES17 measurement filter). Specification provided by ICEpower. See ICEpower datasheets for 125ASX2 and 250ASX2 for full specifications.

6.2 MOUNTING DIMENSIONS

6.2.1 PWR-ICE125

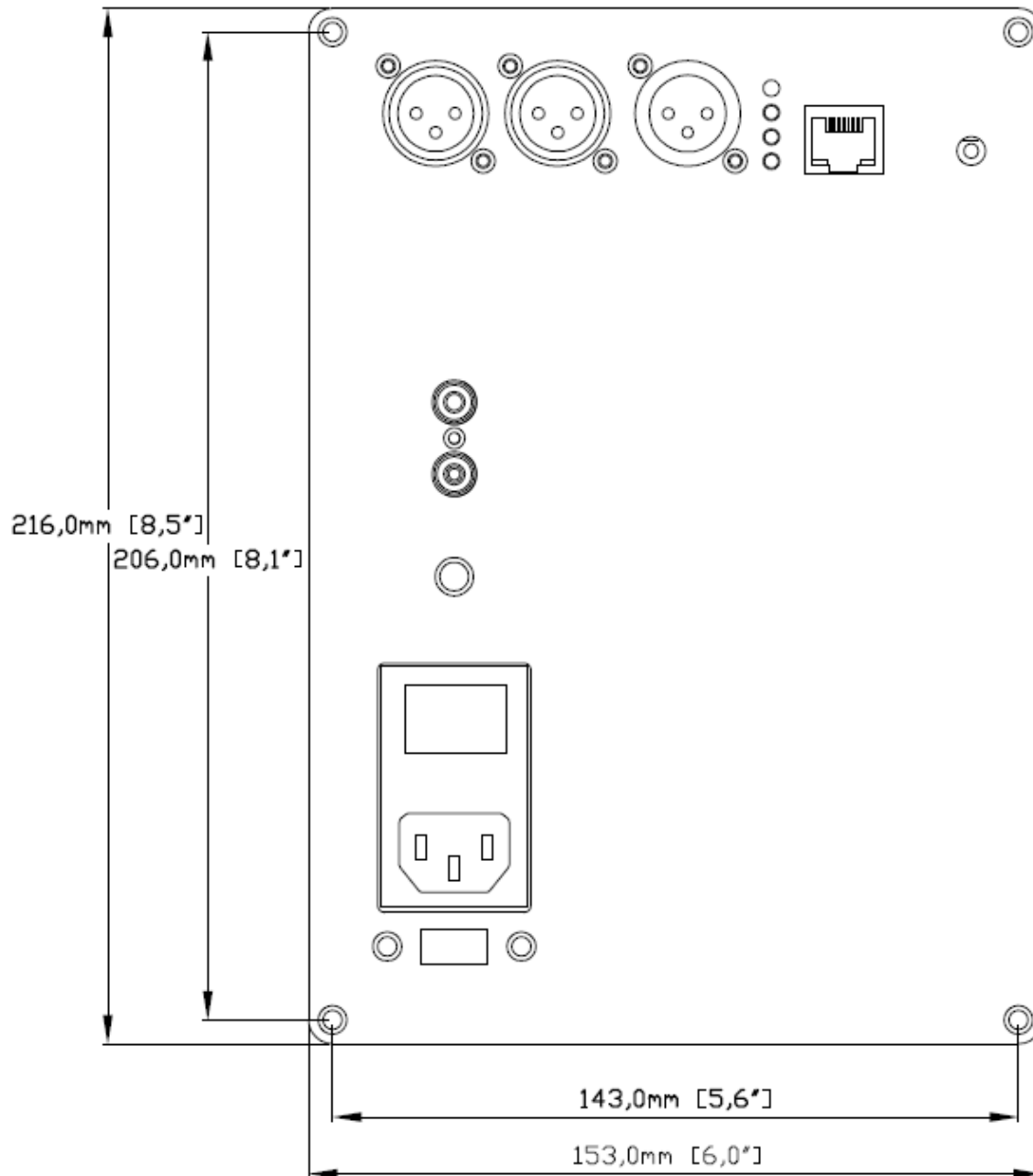

Figure 1. PWR-ICE125 plate dimensions and mounting hole locations

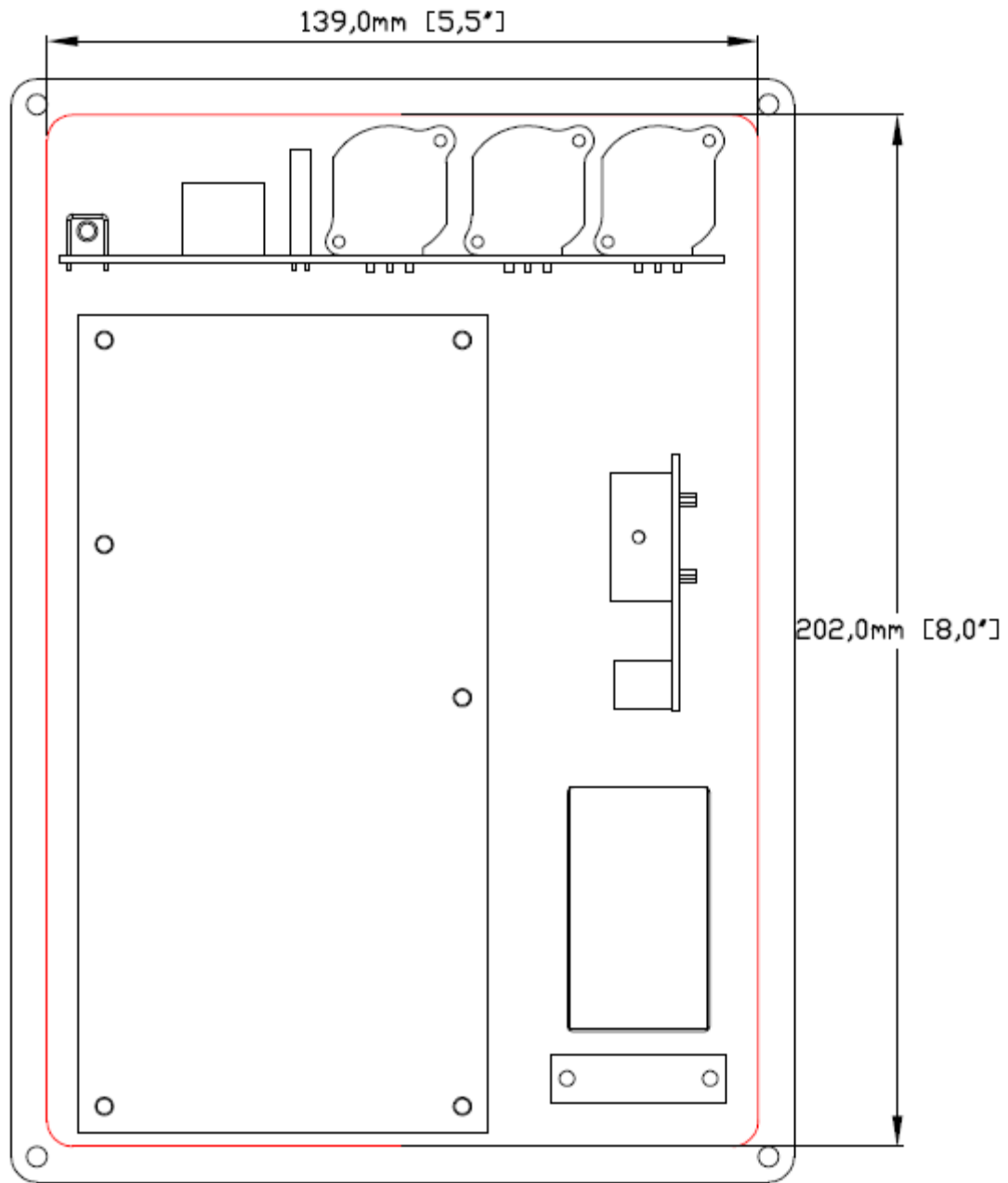

Figure 2. PWR-ICE125 recommended cutout dimensions (red outline)

6.2.2 PWR-ICE250

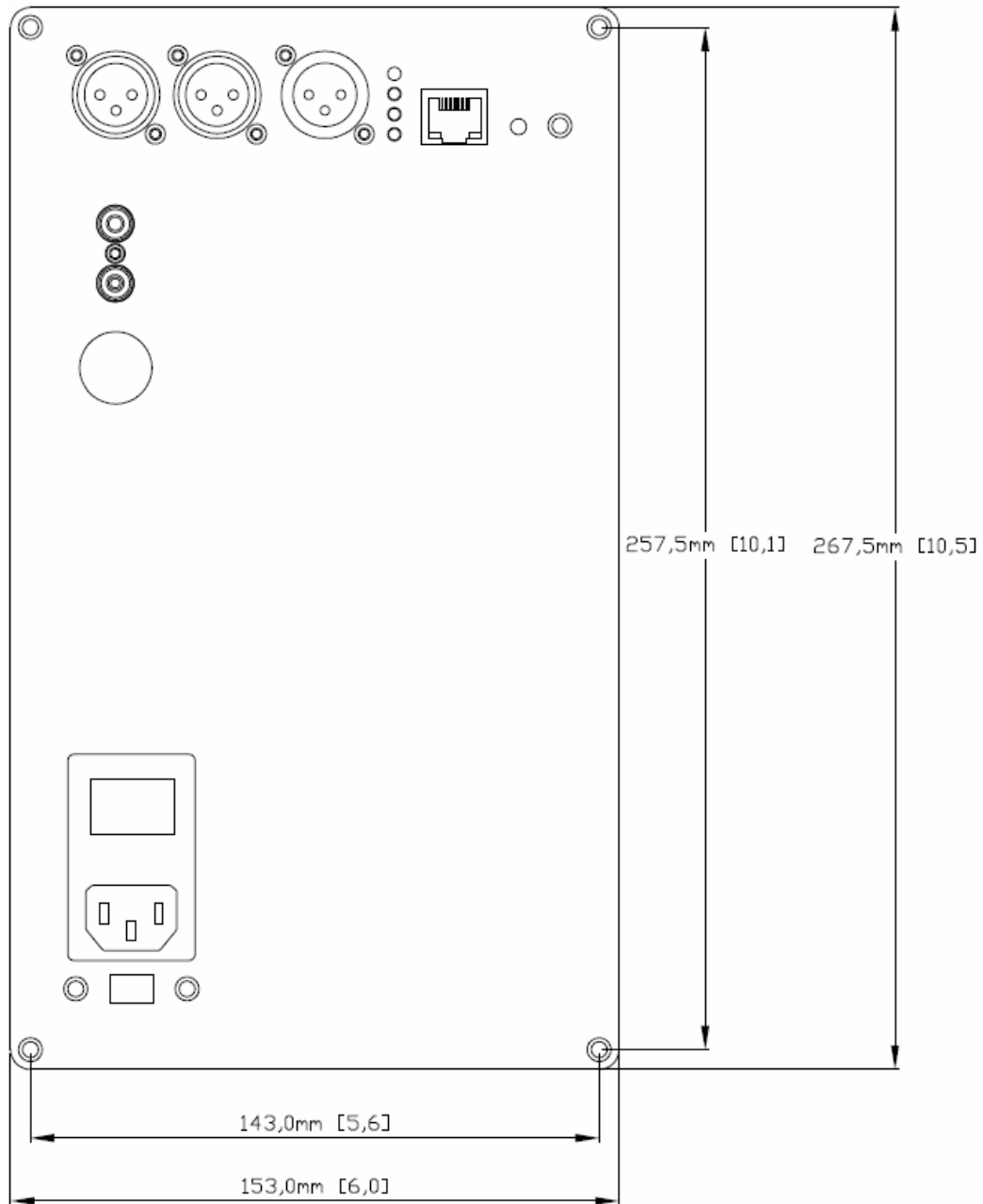

Figure 3. PWR-ICE250 plate dimensions and mounting hole locations

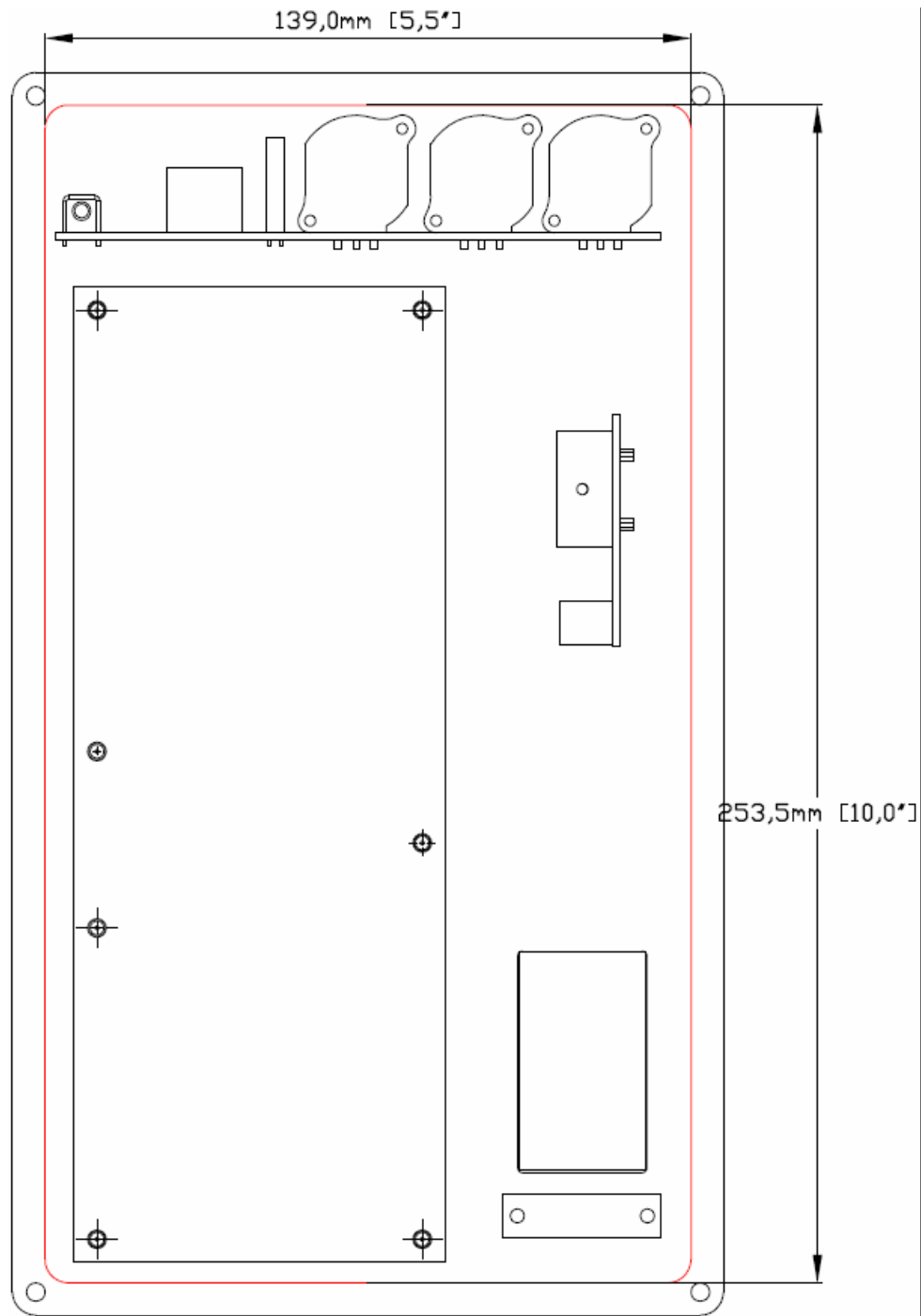
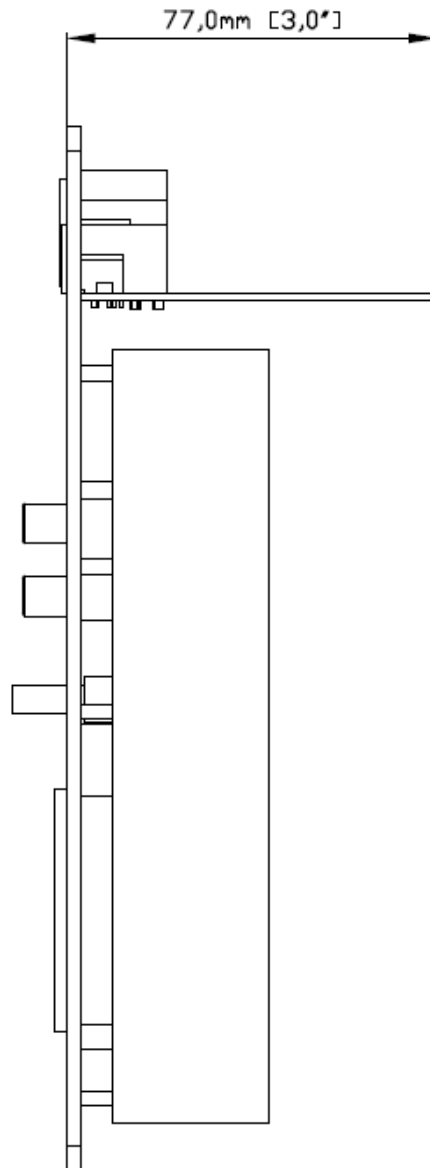

Figure 4. PWR-ICE250 recommended cutout dimensions (red outline)

6.2.3 Additional mounting considerations

Please note the following points:

1. The minimum depth from the front plate is 77mm (3 inches).
2. The plate is not sealed or airtight. Mounting directly into a sealed loudspeaker enclosure is therefore not recommended. Instead, a sub-enclosure should be used.
3. Adequate space and airflow must be allowed around the amplifier to aid cooling. If a separate sub-enclosure is used, ensure that air can flow around the amplifier module.
4. It must not be possible to touch any exposed high voltage parts of the amplifier while it is powered on. (For example, if a subwoofer has a sufficiently large port, ensure that it is not possible to insert a hand and touch the high voltage parts.) See page 15 for locations of high-voltage parts.



6.3 MCU FIRMWARE UPGRADE

To update the MCU firmware, first download **and install** the latest version of the **PWR-ICE2-2x2** or **PWR-ICE2-2x2-FIR** plugin from the **User Downloads** section of the miniDSP website.

Unzip the download file and navigate to the **firmware** folder. There you will see the firmware update file:

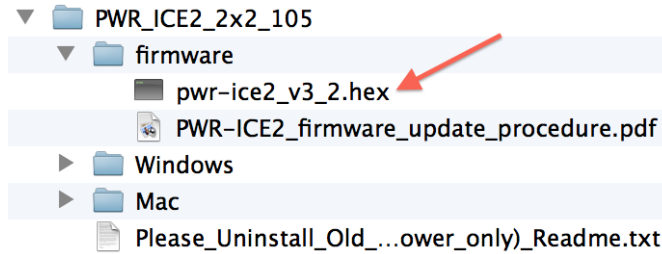

6.3.1 Put the amp into bootloader mode

To put the amplifier into boot loader mode and obtain its IP address:

1. Start the plugin and connect to the amplifier by clicking on its name under “Ethernet Device.”
2. Drop down the Restore menu and select “Upgrade Firmware.”
3. The following dialog appears with the command to use and the IP address of the amplifier:



4. On the panel of the amp, the source selection LED will extinguish to indicate that the amplifier is in boot loader mode. The orange LED on the Ethernet jack will flash intermittently.

6.3.2 Windows

Open a command prompt. (For example, press the “Win” and “R” keys, then type “cmd” and click OK.) In the examples that follow, black text is the “prompt” printed by Windows, blue text is text typed in by you, and red text is the program output.



It is important that you type exactly as shown including characters like “.” and “\” where noted. Press the Tab key after typing the first two characters of any filename, to activate auto-completion.

Assuming that the unzipped download is in the Downloads folder of your home directory, you can type:

```
C:\Users\User> cd Downloads\PWR_ICE2_2x2_105\firmware
C:\Users\...\firmware> dir
...
11/18/2016  06:40 PM                309,796 PWR-ICE2_firmware_update_procedure.pdf
11/18/2016  06:40 PM                276,540 pwr-ice2_v3_2.hex
...
C:\Users\...\firmware>
```

(The version number “105” may be different.)

You can see in the above list the name of the firmware file, **pwr-ice2_v3_2.hex** (the version number “v3_2” may change). Now type the following sequence of commands. Instead of “192.168.1.15” type the number revealed in the instructions above, and be sure also to type the correct firmware file name:

```
C:\Users\...\firmware> tftp 192.168.1.15 put pwr-ice2_v3_2.hex
Transfer successful, 2765400 bytes in 12 second(s), 23045 bytes/s
C:\Users\...\firmware>
```

While the firmware is downloading, the orange LED of the Ethernet jack will light. The download should take about ten to twenty seconds.

Power off the amplifier, wait a few seconds, and then power it on again. You can now proceed to use it as normal.

6.3.3 Mac

To load firmware using Mac OS X requires that you use the Terminal program (located in the Applications/Utilities folder). In the examples that follow, black text is the “prompt” printed by Terminal, blue text is text typed in by you, and red text is the program output.



It is important that you type exactly as shown including characters like “.” and “/” where noted. Press the Tab key after typing the first two characters of any filename, to activate auto-completion.

Assuming that the unzipped download is in the Downloads folder on your Mac, you can type:

```
mac:~ me$ cd Downloads/PWR_ICE2_2x2_105/firmware/
mac:firmware me $ ls
PWR-ICE2_firmware_update_procedure.pdf
pwr-ice2_v3_2.hex
mac: firmware me $
```

(The version number “105” may be different.)

You can see in the above list the name of the firmware file, **pwr-ice2_v3_2.hex** (the version number “v3_2” may change). Now type the following sequence of commands. Instead of “192.168.1.15” type the number revealed in the generic instructions above, and be sure also to type the correct firmware file name:

```
mac:firmware me$ tftp 192.168.1.15
> binary
> rexmt 1
> timeout 60
> put pwr-ice2_v3_2.hex
Sent 276540 bytes in 15.8 seconds
> quit
mac:firmware $
```

While the firmware is downloading, the orange LED of the Ethernet jack will light. The download should take about ten to twenty seconds.

Power off the amplifier, wait a few seconds, and then power it on again. You can now proceed to use it as normal.

6.4 TROUBLESHOOTING

The following table lists the most common causes of issues with the PWR-ICE amplifier. If following this table does not provide a solution, see [Obtaining Support](#) below.

Item#	Symptoms	Troubleshooting recommendation
1	Cannot install the software	a. Confirm that you installed the required frameworks (see Installation – Windows)
2	Plugin does not detect amplifier when connected via network router	<ul style="list-style-type: none"> a. Power-cycle the amplifier (turn it off, wait a few seconds, then turn it on again). b. Check your IP settings, if no DHCP server is present, make sure your computer is not set to use a static address. c. On WinXP, confirm that you have installed the .net environment. d. Confirm that you do not have a firewall blocking the communication.
3	Plugin does not detect amplifier when directly connected with Ethernet cable	a. Disable other network interfaces on your computer (e.g. Wi-Fi).
4	Cannot reload configuration	<ul style="list-style-type: none"> a. Confirm the file format of your file (.xml) b. Confirm the version of the file
5	No audio on RMS input meters	<ul style="list-style-type: none"> a. Check your connectivity b. Double-check the strength of your input signal. c. Confirm that master mute is disabled
6	No audio on outputs	<ul style="list-style-type: none"> a. Make sure that audio signal is shown on the RMS input meters. b. Confirm the source selection is correct (Analog/Digital) c. Double check that output mute buttons are not enabled d. Confirm that master mute is not enabled e. Confirm that you are synchronized and live
7	Audio on input RMS meters but no audio on outputs	<ul style="list-style-type: none"> a. Make sure the matrix mixer is set to send audio to the output channels in a mixer plug-in b. Check the output mute status for each channel



6.5 OBTAINING SUPPORT

1. Check the forums on minidsp.com to see if this issue has already been raised and a solution or solutions provided.
2. Contact miniDSP via the support portal at support.minidsp.com with:
 - a. The specific product you are having an issue with (in this case, PWR-ICE amplifier).
 - b. A clear explanation of the symptoms you are seeing.
 - c. A description of the troubleshooting steps (see Troubleshooting above) you performed and the results obtained.